



Installation manual **EN**

Clamping device

TOROK

Table of contents

1	General.....	4
1.1	Information about this manual.....	4
1.2	Explanation of symbols.....	4
1.3	Limitations of liability.....	5
1.4	Max. RPM.....	6
1.5	Copyright.....	6
1.6	Scope of delivery.....	7
1.7	Spare parts.....	7
1.8	Warranty terms.....	7
1.9	CFK.....	7
2	Safety.....	8
2.1	Responsibility of the customer.....	8
2.2	Personnel requirements.....	8
2.3	Intended use.....	9
2.4	Personal protective equipment.....	10
2.5	Special dangers.....	11
2.6	Further warnings.....	14
2.7	Clamping force.....	16
2.8	Screws.....	16
2.9	Functionality.....	17
2.10	Environmental protection.....	17
3	Technical data.....	18
3.1	General Information.....	18
3.2	Clamping force diagram TOROK.....	19
3.2.1	Clamping force diagram – TOROK size 65 RD.....	20
3.3	Operating conditions.....	21
3.4	Power specifications.....	21
3.5	Check.....	21
3.6	Type designation.....	21
4	Structure and function.....	22
4.1	Overview and brief description.....	22
4.2	Optional Accessories.....	23
4.2.1	Clamping head.....	23
4.2.2	Changing fixture.....	24
4.2.3	Work piece end-stop.....	24
4.2.4	Chip guard bushing.....	24
4.2.5	Key.....	25
4.2.6	Torque wrench set.....	25
4.2.7	Grease.....	25
4.2.8	Grease gun.....	25
5	Transporting, packaging and storing.....	26
5.1	Safety instructions for transporting.....	26
5.2	Symbols on the packaging.....	26
5.3	Transport inspection.....	27
5.4	Unpacking and inner-company transportation.....	27
5.5	Packaging.....	28
5.6	Storing.....	29

6	Assembly.....	30
6.1	Pre-consideration.....	30
6.2	Preparations.....	31
6.3	Installation.....	32
6.3.1	Assembling the flange [optional].....	34
6.3.2	Assembly of the TOROK.....	34
6.3.3	Checking and adjusting the face run and the concentricity.....	36
6.3.4	Assembly of the changing parts.....	37
6.3.5	Assemble / disassemble the clamping head.....	39
6.4	Work piece.....	40
6.4.1	Add on clamping element MANDO Adapt.....	42
6.4.2	Add on clamping element jaw module.....	42
6.5	Inspections.....	43
6.6	Control of the stroke position.....	44
6.7	Activities after production is concluded.....	44
7	Disassembly.....	45
7.1	Safety.....	45
7.2	Disassembling the clamping device.....	46
7.2.1	Disassembling the changing parts.....	46
7.2.2	Disassembly of the TOROK.....	47
7.2.3	Disassembling the flange [optional].....	50
7.3	Subsequent storage of the clamping device.....	51
7.4	Disposal.....	51
8	Maintenance.....	52
8.1	General.....	52
8.2	Cleaning.....	53
8.3	Preservation.....	54
8.4	Use of lubricant.....	54
8.4.1	Lubrication.....	55
8.4.2	Lubrication interval.....	55
8.5	Maintenance schedule.....	55
8.6	Bolt torque.....	56
9	Trouble shooting.....	57
9.1	Safety.....	57
9.2	Trouble shooting table.....	58
9.3	Start-up after corrected fault.....	59
10	Appendix.....	60
10.1	Service Hotline.....	60
10.2	Representatives.....	60
10.2.1	Europe.....	60
10.2.2	America.....	63
10.2.3	Asia.....	63
10.2.4	Australia.....	64
10.2.5	Africa.....	64
	Index.....	66
	EC Declaration of conformity.....	68

1 General

1.1 Information about this manual

This manual enables safe and efficient handling of the clamping device.

The manual is a component of the clamping device and must be kept in the immediate vicinity of the clamping device where it is accessible for personnel at all times. Personnel must have carefully read and understood this manual prior to starting all tasks. The basic prerequisite for safe work is compliance with all the safety instructions and handling instructions in this manual.

Illustrations in this manual are provided for a basic understanding and may deviate from the actual model of the clamping device.

It is assumed that the reader is familiar with standard procedures, such as cleaning the mounting surfaces.

1.2 Explanation of symbols

Safety instructions

Safety instructions are indicated by symbols in this operating manual. The safety instructions are introduced by signal words that express the scope of the hazard.

The safety instructions must be strictly adhered to. You must act prudently to prevent accidents, personal injury, and material damage.



DANGER

... indicates an imminent dangerous situation than can result in death or serious injury if it is not avoided.



WARNING

... indicates a possible dangerous situation that can result in death or serious injury if it is not avoided.



CAUTION

... indicates a possible dangerous situation that can result in minor or light injury if it es not avoided.



NOTE

... indicates a possible dangerous situation that can result in material damage if it is not avoided.

Tips and recommendations



... indicates useful tips and recommendations, as well as information for efficient and trouble-free operation.

1.3 Limitations of liability

All information and instructions in this operating manual have been provided under due consideration of applicable standards and regulations, the current state of technology, as well as our many years of experience.

The manufacturer assumes no liability for damage due to:

- Failure to follow the instructions in the manual
- Non-intended use
- Deployment of untrained personnel
- Unauthorized conversions
- Technical changes
- Use of non-approved spare parts

The actual scope of delivery can vary from the explanations and graphic representations provided in this manual in the case of special versions, if supplemental order options are desired, or on the basis of the latest technical changes.

The agreed obligations in the delivery contract, the general terms and conditions, as well as delivery conditions of the manufacturer, and the statutory regulations valid at the time the contract was concluded, apply.



CAUTION!

Our clamping devices are balanced with balance quality $G = 4$, in one level $n = 1$.

The data on the rotation balance refers to rotationally symmetrical work pieces.

The clamping of not rotationally symmetrical work pieces may not be clamped and/or only be clamped after consultation with the manufacturer.

Balancing bolts and balancing weights at the clamping devices may not be removed / disassembled!

1.4 Max. RPM



CAUTION!

The maximum permissible speed is marked on the product.

By the combination of a clamping device and an add on clamping element a reduction of the maximum permissible speed may be necessary.

- Of all RPMs of the groups specified, the **lowest given RPM** must always be used.

Note that the clamping force is influenced by the centrifugal force of the clamping elements.

- If necessary, adjust the machining force!

1.5 Copyright

This manual is protected by copyright and is provided exclusively for internal purposes.

Delivery of the operating manual to third parties, duplication in any form – including excerpts – as well as exploitation and/or communication of the content, are not permitted [except for internal use] without written approval from the manufacturer.

Actions to the contrary make damage compensation mandatory. We reserve the right to enforce additional claims.

1.6 Scope of delivery



All tools and accessories that are not included in the scope of delivery are marked as optional.

In scope of delivery of the clamping device:

- 1 TOROK
- 1 Base end-stop
- 1 Socket wrench

Optionally the scope of delivery of the clamping device includes:

- Flange
- Clamping head
- Workpiece end-stop
- Eye bolts
- Control ring
- Torque wrench set

1.7 Spare parts



WARNING!

Safety risk if the wrong spare parts are used!

Incorrect or defective spare parts can cause damage, malfunction, or total failure; they can also impair safety.

- Only use manufacturer's original spare parts.

Only purchase spare parts from authorized dealers or direct from the manufacturer. Addresses are in the appendix.

1.8 Warranty terms

The warranty terms are included in the manufacturer's terms and conditions.

1.9 CFK



In case of visible damage or visible wear of the carbon parts:

- Further processing only after consultation with HAINBUCH.

2 Safety

This section provides an overview of all the important safety aspects for optimal protection of personnel, as well as for safe and trouble-free operation.

2.1 Responsibility of the customer

The device is used in industrial applications. Consequently the owner of the device is subject to legal industrial safety obligations.

In addition to the safety instruction in this manual, generally valid safety and accident protection guidelines, and environmental protection guidelines as well as the machines' manual must be adhered to and complied with for the area of implementation of the device.

The achievable clamping forces can vary due to the maintenance condition of the clamping device or the adapter [lubrication condition and degree of contamination], [see chapter »Maintenance«].

Pay attention to chapter 3.2 clamping forces TOROK!



WARNING!

Risk of injury!

Declining operating force, for example by declining energy supply, may cause serious personal injury.

- The product may be used only on machines where it is ensured, that during use, the operating force does not drop.

2.2 Personnel requirements



WARNING!

Danger of injury due to insufficient qualification!

Improper handling of the clamping device can cause serious injury or material damage.

- Only have activities performed by personnel who are qualified to perform these activities.

The following qualifications are cited in the operating manual for the various activity areas.

- **Specialized personnel**

are personnel who due to their specialized training, skills, and experience, as well as knowledge of the applicable regulations, are capable of executing the tasks assigned to them and of recognizing and avoiding possible hazards on their own.

- **Hydraulic specialist**

The hydraulic specialist has been trained for the particular task area in which he is active and is familiar with the relevant standards and regulations. Due to his specialized training and experience the hydraulic specialist can perform tasks on hydraulic equipment and recognize and avoid possible dangers on his own.

- **Electric specialist**

The electric specialist has been trained for the particular task area in which he is active and is familiar with the relevant standards and regulations.

Due to his specialized training and experience the electric specialist can perform tasks on electric equipment and recognize and avoid possible dangers on his own.

Only persons from whom it can be expected that they reliably execute their work are considered as personnel. Persons whose capability to react is impaired, for instance through drugs, alcohol, or medication, are not approved.

- Comply with age-specific and job-specific regulations that are applicable at the installation site when selecting personnel.

2.3 Intended use

The clamping device is designed for installation in a machine tool according to CE compliant. Within the machine tool the clamping device is designed exclusively as a through-bore chuck for bar work and / or as an end-stop chuck for chuck work.

The clamping device should only be mounted, operated, maintained, and cleaned by instructed, specialized personnel.

Intended use also includes compliance with all the instructions in this manual.

The clamping device is to be used for the case of application contractually agreed between the producer/deliverer and the user, as well as such cases of application described in the product description which are also in accordance with the technical values.

The safe function of the clamping device is, as far as it can be foreseen, guaranteed when it is used for the intended purpose in accordance with the appropriate safety regulations.

Any use that extends beyond the intended use, or any other use of the clamping device is considered to be misuse and can cause dangerous situations.



WARNING!

Danger due to misuse!

Misuse of the clamping device can cause dangerous situations.

Particularly refrain from the following uses of the clamping device:

- Use in machines other than machine tools.
- Use in machine tools with technical data other than that specified on the clamping device.

Claims of any type due to damage arising from non-intended use are excluded.

Unintended and improper use of the Power Chuck is for example

- If workpieces are not clamped properly
- If safety regulations are disregarded and persons are working at the clamping device without additional protective devices e.g. for machining.
- If the clamping device is used for machines or tools for which it is not intended.

2.4 Personal protective equipment

Wearing of personal protective equipment is required to minimize health hazards when working with the device.

- Always wear the protective equipment necessary for the respective task when working with the device.
- Follow the instructions that have been posted in the work area.

Always wear



For all tasks always wear:

Protective work clothing

is tight-fitting work clothing with low resistance to tearing, with tight sleeves, and without projecting parts. It is primarily used to protect against entanglement by moving machine parts.

Do not wear rings, chains, or other jewelry.



Safety footwear

for protection against heavy falling parts and slipping on slippery substrates.

For special tasks wear



Special protective equipment is required when executing special tasks. Separate reference is made to this equipment in the specific sections of this manual. This special protective equipment is explained below:

Hard hat

to protect against falling and flying parts and materials.



Protective goggles

to protect eyes from flying parts and liquid splashes.



Protective gloves

to protect hands from friction, abrasion, puncture wounds, or deeper injuries, as well as from contact with hot surfaces.

2.5 Special dangers

In the following section residual risks are cited that occur due to installation of the clamping device in a machine tool. In each case the residual risks that have been determined based on a risk analysis of the machine must be specified by the customer.

- Follow the safety instructions listed here and the warnings in the other sections of this manual to reduce health hazards and to avoid dangerous situations.

Horizontal / lying parts



WARNING!

Danger of injury due to horizontal parts!

Before transporting the clamping device in horizontal condition:

- Put the clamping device on a non-slip pad
- Screw in the eye bolts

Suspended loads



WARNING!

Life-threatening danger due to suspended loads!

Some clamping devices must be lifted with a crane. When lifting the clamping device there is a life-threatening hazard due to falling parts or parts swinging out of control.

- Never step under suspended loads.
- Comply with the instructions concerning the intended attachment points. Ensure that the sling gear is securely seated!
- Do not attach lifting gear in projecting components.
- Only use approved hoists and sling gear with sufficient bearing capacity.
- Do not use rope and belts that are torn or frayed.

Moving parts



WARNING!

Danger of injury due to moving parts!

Rotating parts of the clamping device can cause serious injuries.

- Do not reach into moving parts or handle moving parts during operation.
- Note the gap dimensions of moving parts.
- Do not open covers when the device is in operation.
- Be aware of after-run time:
Prior to opening the covers ensure that all parts have come to a standstill.
- Wear tight-fitting protective work clothing in the danger zone.

Wrong clamping of the work piece

Clamping position

Position with workpiece

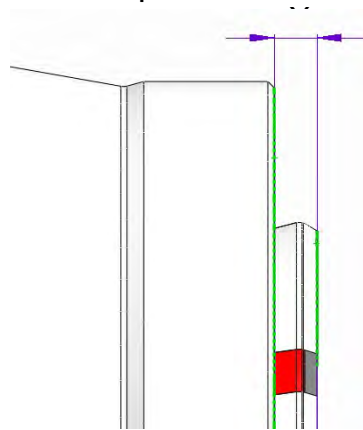

Fig. 1

End position

End position without workpiece X_1

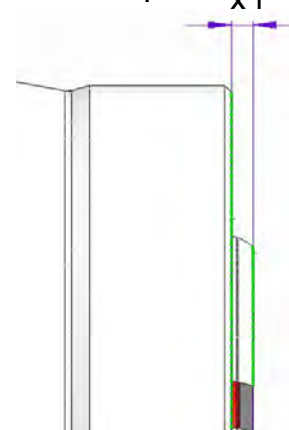

Fig. 2



WARNING!

Danger of injury due to incorrect clamping of the work piece!

Incorrect work piece clamping may lead to the ejection of the work piece and result in serious injuries.

The use of more than 75% of the clamping reserve stroke may lead to wrong clamping.

- Do not exceed the maximum permissible clamping reserve stroke.
Calculation basis: $[X-X_1] \times 75\%$
- Check the workpiece blanks dimension randomly.

Missing changing parts



WARNING!

Danger of injury due to missing changing parts!

When operating the clamping device without changing parts [segmented clamping bushing, clamping heads, work piece end-stops] there is a higher danger of crushing injuries due to the stroke of movable components of the clamping device.

- The clamping process may not be initiated without assembled segmented clamping bushing and/or work piece end-stop.

Parts with sharp edges



WARNING!

Risk of injury!

When screwing in individual components such as for example work piece end-stops, threaded adapters and similar devices that are equipped with an external thread or wear caused by burrs, there is risk of cutting.

- The operation must be done only by qualified personnel.
- Wearing of gloves / [PSA] is required!



CAUTION!

Risk of injury!

A special use-dependent or job-based design can result in variations in the clamping strokes and thus the clamping force.

- The notes on the associated clamping situations or product drawing must always be observed

2.6 Further warnings



WARNING!

Risk of injury!

Never reach for the clamping device while the spindle is rotating. Before starting to work on the mandrel, make sure the machine spindle cannot be put in motion.



WARNING!

Risk of injury!

Falling down of the clamping device or its parts can cause severe bruises and fractures.

The dead weight of the clamping device or its parts can lead to high physical stress.



WARNING!

Risk of injury!

By repeated reworking or wear and tear of the clamping surfaces sharp edges and burrs may appear and lead to severe cutting damages.



WARNING!

Risk of injury!

Missing o-rings or seals may cause severe injuries!

Due to missing / fallen out O-rings and seals compressed air or hydraulic fluids which are under high pressure may expel!

- Make sure that all O-rings / seals for the hydraulic / pneumatic connections are available and undamaged!
- If necessary lubricate them before assembly and/or during service.



Risk of injury!

Leaking [sprayed out] hydraulic oil can cause serious injury.

- Make sure that all O-rings / seals for the hydraulic and/or pneumatic connections are available and undamaged



WARNING!

Damage of clamping device!

The clamping device may be released exclusively in the standing condition!

2.7 Clamping force

The achieved clamping force can vary due to the maintenance condition of the clamping device [state of lubrication and degree of contamination] [see chapter »Maintenance«].

The clamping force must be checked at regular intervals. This requires the use of static clamping force measuring devices.



CAUTION!

Damages due to excessive draw and compressive force!

An excessive draw force and/or compressive force may damage the clamping device.

- The max. draw force and compressive force may not be exceeded.

2.8 Screws

Moving parts



WARNING!

Danger of injury due to screws and stud screws being accelerated out of the device!!

Screws and stud screws radially attached to the product can be accelerated out of the device and cause severe injuries.

- At the product radially mounted screws and stud screws which were loosened for assembly and maintenance must be re-tightened with the correct tightening torque!
The tightening torque is given at the product itself, near the screw or threaded pin, and/or given in chapter »Bolt torque«.
- All screws or stud screws that are not marked with a tightening torque specification are tightened with the prescribed tightening torque and locked [medium-strength bonding] in the factory and should only be unscrewed after consultation with the manufacturer. If in doubt you must contact the manufacturer immediately do determine the subsequent procedure.

2.9 Functionality



NOTICE!

With high contamination of the clamping device the functionality is no longer guaranteed.

- The cleaning and maintenance intervals must be observed.

2.10 Environmental protection



NOTE!

Environmental hazard due to incorrect handling!

Incorrect handling of environmentally hazardous substances, particularly improper disposal, can cause significant environmental damage.

- Always comply with the instructions cited below
- If environmentally harmful substances should inadvertently get into the environment, initiate suitable measures immediately. If in doubt notify the responsible municipal authority about the damage.

The following environmentally harmful substances are used:

Lubricants

Lubricants like greases and oils can contain toxic substances. Ensure that they do not get into the environment.

The device must be disposed of by a specialized disposal company.

To achieve trouble-free operational performance of the clamping device only use HAINBUCH lubricants. See the appendix for reference addresses.

3 Technical data

3.1 General Information

The clamping device is available in different sizes and variants.

Information about e.g.

- dimensions
- weight

you will find on the corresponding drawing that you can order at HAINBUCH.

Size	Weight [kg]	Dimensions [ø x Length in mm]	Spindle flange connection [ø in mm]	Speed max. [1/min]	Clamping force F_{rad} max. [kN]	Clamping force F_{ax} max. [kN]	Tightening torque max. [Nm]
65 RD	16	ø 187 x 120	IP 162	6000	71	31	62

IP = Inner fit dimensions

F_{rad} max. can only be reached in lubricated condition.
In unlubricated condition F_{rad} max. is much lower.



WARNING!

Risk of injury!

Using false technical data can lead to serious personal injury and property damage.

- The technical data [label on the product, assembly drawing] must be observed and may not be modified by the operator!

3.2 Clamping force diagram TOROK

In the diagrams, the effects of friction and the clamping diameter are included.



NOTE!

The measured values for the radial clamping force F_{rad} may not leave the permitted area. Under optimal conditions, the values for F_{rad} are below the top, in bad conditions above the lower limit.

- If the measured clamping forces are outside the allowed range, the maintenance is mandatory to perform. After servicing, the clamping forces have to be re-examined.
- If the clamping force even after the maintenance is not in the permitted area please contact the manufacturer.

Example

1. With an initiated torque of 30 Nm the radial force F_{rad} is, depending on the maintenance state of the clamping device, in the range between 22 kN and 42,5 kN.

When using an adaptation clamping device the axial force F_{ax} is required. With the same torque of 30 Nm an axial force F_{ax} of 16 kN is reached.

2. If F_{ax} (ax) is required, e.g., 20 kN, a torque of 36 Nm is necessary.

Remarks

In the diagram the influence of the friction and the clamping diameter are taken into account.

Under perfect conditions, the values for F_{rad} are in the region of the upper limit, with bad conditions in the region of the lower limit.

3.2.1 Clamping force diagram – TOROK size 65 RD

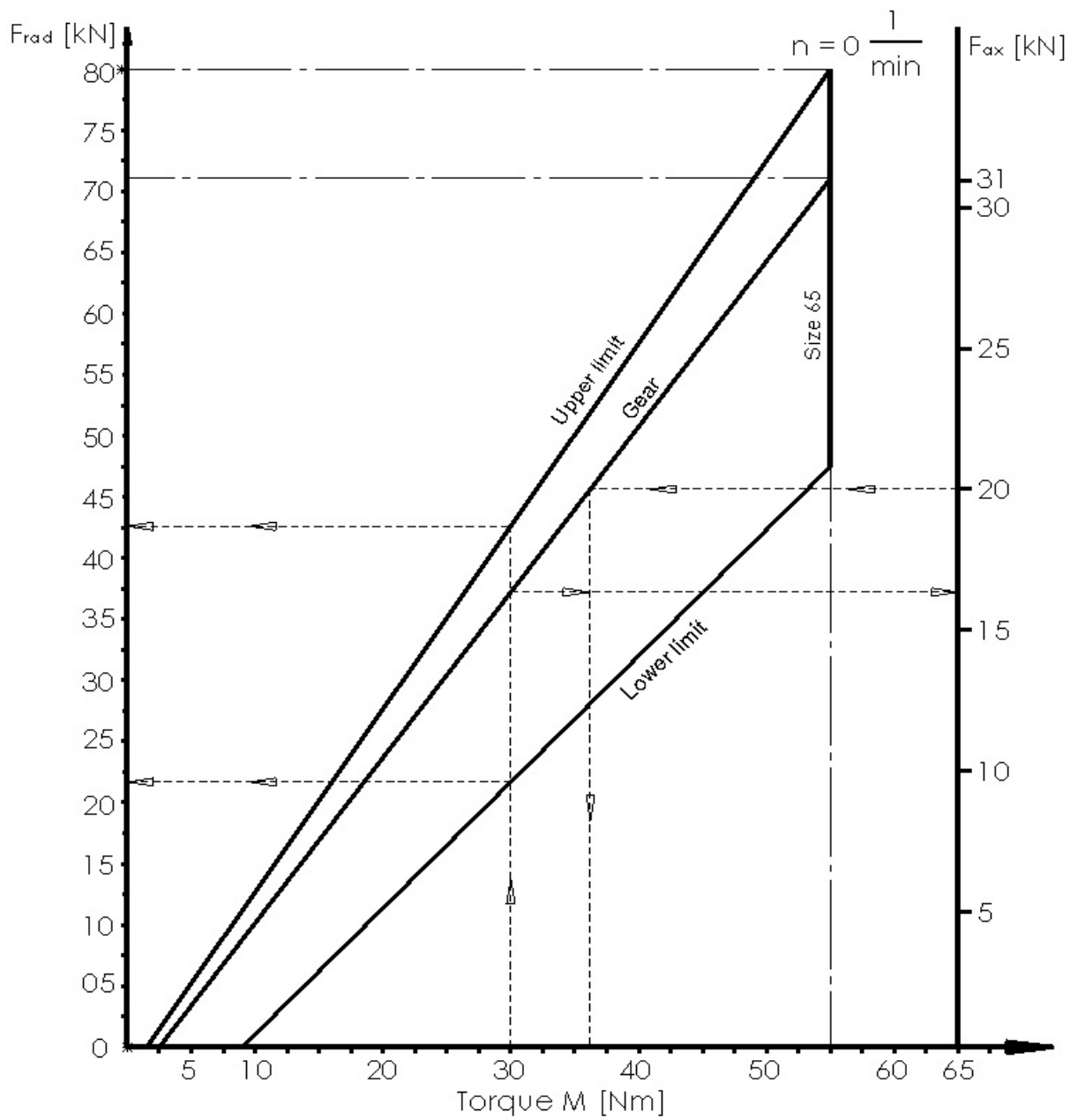

Fig. 3

3.3 Operating conditions

Environment	Specification	Value	Unit
	Temperature range	15 - 65	°C

Mechanical actuating In each possible operating condition the maximum draw force and compressive force may not be exceeded!

3.4 Power specifications



NOTE!

Material damage if the power specifications do not agree!

If the power specifications of clamping device, machine adapter and machine do not agree, severe damage extending to total damage can occur.

- Only operate clamping devices and adapters in machines with the same power specifications.

Information on maximum clamping force and draw tube force is provided on the clamping device and the adapter.

3.5 Check

Static test Used coefficient: **1.25**

3.6 Type designation

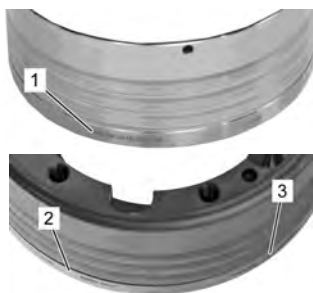

The type designation is on the product and includes the following information:

- 1 ID no. [marked with the # symbol]
- 2 Maximum speed [rpm]
- 3 Maximum clamping force [kN]

Fig. 4

4 Structure and function

4.1 Overview and brief description



Fig. 5

1. TOROK
2. Clamping head

3. Actuating wrench

Brief description

The TOROK manual chuck is primarily used in tool prototyping on machines without a clamping cylinder. Basically, it is implemented wherever users are reluctant to sacrifice the accustomed SPANNTOP quality even without a clamping cylinder.

Best of all:

due to its easy manual activation you can clamp safely and delicately, for example, when used on grinding machines. With an optional base plate, the TOROK can also be used stationary very quick.

More clamping options in combination with clamping device adaptations:

In combination with our clamping device adaptations,

such as the mandrel-in-chuck MANDO Adapt or the jaw module, it opens up even much more clamping options.

Key advantages

- Sensitive manual clamping is possible
- Manual activation – a clamping cylinder is not required
- Concentric precision < 0.01 mm possible
- Minimal inertia loss
- Standard flanges available with adjustable bolt, Camlock upon request

4.2 Optional Accessories

The accessories described here are not included in the scope of delivery.

Specially developed segmented clamping bushings match to the respective maximum RPM are available for each clamping device. Trouble-free and precise function of HAINBUCH clamping devices is only ensured when using original HAINBUCH segmented clamping bushings.

Lubricating grease and grease gun are required for cleaning and preservation of the clamping device. The lubricating grease is also specially matched for protection of the vulcanized segments of the segmented clamping bushings and increase their service life and elasticity by a significant factor.

4.2.1 Clamping head



Fig. 6

The clamping heads are used to accommodate the work piece that will be machined. They consist of hard steel and rubber segments that are connected via a vulcanizing process.

Depending on the requirements of the work piece there are clamping heads in different sizes and with different profiles and bores.

4.2.2 Changing fixture



Fig. 7

Manual changing fixture

The pins of the changing fixture are inserted in the matching holes in the clamping head. The changing fixture is tensioned via hand force. The clamping head is firmly clamped in the changing fixture and can be inserted into the mounted clamping device with the aid of the changing fixture.



Fig. 8

Pneumatic changing fixture

The pins of the changing fixture are inserted in the matching holes in the clamping head. The changing fixture is tensioned via compressed air. The clamping head is firmly clamped in the changing fixture and can be inserted into the mounted clamping device with the aid of the changing fixture.

4.2.3 Work piece end-stop

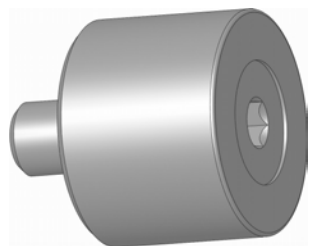

Fig. 9

The work piece end-stop is manufactured with a end-stop dimension according to the customers request. In combination with the clamping head and the chuck it provides a functional unit.

4.2.4 Chip guard bushing



Fig. 10

For the use of the clamping device as through-bore chuck the existing base end-stop must be replaced by a chip guard bushing.

The chip guard bushing has the order number 40511.90/0025, it can be ordered from HAINBUCH.

4.2.5 Key

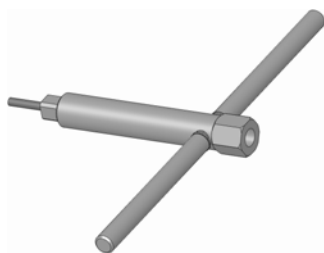

Fig. 11

The key has the order number NH.611/0002, it can be ordered from HAINBUCH.

4.2.6 Torque wrench set



Fig. 12

Depending on the scope of the order, the torque wrench set can be supplied or provided by the customer. The set has the order number 2012/0005, it can be ordered from HAINBUCH.

4.2.7 Grease



Fig. 13

The universal grease for chuck and mandrel lubrication is supplied in a 1000g can. The order number for the universal grease is 2085/0003; it can be ordered from HAINBUCH.

4.2.8 Grease gun



Fig. 14

The grease gun is filled with universal grease, which is pressed into the clamping device. The grease gun has a pointed mouthpiece. The order number for the grease gun is 2086/0004; it can be ordered from HAINBUCH.

5 Transporting, packaging and storing

5.1 Safety instructions for transporting

Unbalanced package



WARNING!

Danger of falling due to an unbalanced package

Packed goods can have an unbalanced package. If attached incorrectly the package can tip and cause life-threatening injuries.

- Note the markings on the packages.
- Attach the crane hook in such a manner that it is located above the center of gravity.
- Carefully lift and see if the load tilts. If necessary change the attachment.



Transport!

- For transport always use a suitable clamping means / crane.
- Make sure that a rolling / falling of the clamping device is not possible.

5.2 Symbols on the packaging



Fragile

Identifies packages with fragile or sensitive contents. Handle the packed goods with care; do not allow them to fall, and do not subject them to impact.



Protect from moisture

Keep packed goods dry and protected against moisture.

5.3 Transport inspection

Check delivery immediately upon receipt to ensure that delivery is complete and to identify any transport damage.

Proceed as follows if there is apparent external damage:

- Do not accept the delivery, or only accept it with reservation.
- Note the extent of transport damage on the transport documents or on the transport company's delivery ticket.
- Submit a complaint.



Report any defect as soon as it is detected. Claims for damage compensation can only be enforced during the applicable periods for giving notice of lack of conformity.

5.4 Unpacking and inner-company transportation



The clamping device is packed vertically and has threaded bores in the end face.

To safely lift the clamping device out of the package it must be hooked into a crane depending on the weight.

For transporting with transport trolley the clamping device must be positioned in standing condition. Make sure that a non-slip pad has been laid.

All tools and optional accessories which are not in scope of delivery, are marked as optional in the installation manual

- Two people are required for this task.
- Special tools required:
 - Crane from weight more than 15 kg
 - Lifting eye bolt



Fig. 15

1. Screw lifting eye bolts into the thread in the end face of the clamping device.
2. Hook the load-handling equipment into the lifting eye bolts.
3. Use a crane to carefully lift the clamping device out of the transport packaging and put it down on a stable, level substrate.

5.5 Packaging

About the packaging

Individual packages are packed according to the expected transport conditions. Environmentally-friendly materials have been used exclusively for the packaging.

Packaging should protect the specific components from transport damage, corrosion, and other damage until installation. Therefore do not destroy the packaging, remove it just before installation.



The packed goods are sealed in foil airtight and packed in cartons. See the »Technical Data« section for the specific weight of the respective sizes.

Handling packaging materials

Dispose of packaging materials in accordance with the respectively valid statutory regulations and local guidelines.



NOTE!

Improper disposal causes environmental damage!

Packaging materials are valuable raw materials and in many cases they can be reused, or they can be effectively treated and recycled.

- Dispose of packaging materials in an environmentally responsible manner.
- Comply with locally applicable disposal guidelines. If necessary commission a specialized company to dispose of packaging.

5.6 Storing



Under certain circumstances instructions for storage and subsequent storage are affixed to the packages that extend beyond the requirements cited here.

Comply with these instructions accordingly.

Storage of packages Only store packages under the following conditions:

- Do not store outdoors.
- Store in a dry and dust-free location
- Do not expose to aggressive media
- Protect from direct sunlight
- Avoid mechanical vibration
- Storage temperature: 15 bis 35 °C
- Relative humidity: max. 60 %
- For storage periods longer than 3 months:
 - Check the general condition of all parts and the packaging at regular intervals.
 - Touch up or re-apply anti-corrosion agents as needed

Subsequent storage of the clamping device

Only re-store the clamping device under the following conditions:

- Thoroughly clean the clamping device prior to subsequent storage [see section »Cleaning«]
- Thoroughly oil and grease the clamping device. [see section »Cleaning«]
- Store the clamping device in airtight foil
- The clamping device must be stored securely in position. If this is not guaranteed, use a suitable container for the clamping device or equip the shelf with a circumferential securing edge.

6 Assembly



WARNING!

During the initial installation of the clamping device severe injuries may occur.

- The initial installation must be done only by qualified personnel.
- All screws remaining in the clamping must be tightened firmly.
- All tools and keys must be removed after installation.

6.1 Pre-consideration

- Screws are tightened according to the size of the screw and the general torque.
To avoid axis-parallel warpage under load and to get stiffness turn in the screws evenly.
- To avoid precision error clean the screw joint surfaces and also the mating surfaces, see »Maintenance«.
The ex works wetting of the plate surfaces and the clamping element is only corrosion protection. It's not functionally lubricated.
- The insertion of lubricant is provided only on the mechanical surfaces. Pay attention to the instructions for lubricants in the chapter »Maintenance«.
- Avoid too much lubricant on the bearing surface, as this can cause face runout.
- Seal rings (e.g. o-ring, quad-ring seal) and sealing surfaces must be lubricated.
Note the information in the chapter »Maintenance«.
- Note that the function surfaces (plate surface, mating surface, cone surface and seal surface) may not be damaged.



CAUTION!

Wear safety shoes during the assembly and maintenance work.

Make sure that the starting of the spindle is impossible.

6.2 Preparations

The total weight of the clamping device, consisting of spindle flange and clamping unit, depends on the size and can be as much as 20 kg [see technical data].

Depending on the weight, to safely lift the clamping device out of the package and position it in the machine and/or on the machine table it must be hooked into a crane.



WARNING!

Danger of injury due to falling components!

When mounting components can fall and cause severe injury and material damage.

- Two people are always required for this task.
- Use a crane.



Damage caused by contaminated surfaces!

Contaminated contact surfaces and scratches can lead to impairment of axial and radial run-out accuracy.

- Clean the bearing surfaces and oil them gently.
- Check the bearing surfaces for scratches and other damage. If necessary, contact the manufacturer.

6.3 Installation



WARNING!

Danger of injury due to unintentional start-up of the tool spindle!

Unexpected start up of the tool spindle can cause severe injury.

- Prior to switching on automatic mode close all protective doors or hoods that are present on the machine tool.
- Unscrew all eye bolts from the clamping device and remove them from the interior of the machine.
- Only run the machine in set-up mode or jog mode.
- Always remove immediately all the tools and wrenches from the clamping device after use.



WARNING!

Risk of injury!

By operating the clamping device without changing parts [clamping head, segmented clamping bushing, work piece end-stops ...] there is an increased risk of crushing injuries by the stroke of the moving components of the clamping device.

By uncontrolled discharge of the clamping process [e.g. by incorrect installation of the energy supply or faulty programming] there is an increased danger.



WARNING!

Risk of injury!

Bending in the working area of the machine can cause severe head injuries!



CAUTION!

Risk of injury!

Unexpected start up of the tool spindle can cause severe injury.

- Make sure that the system is pressure-free and that a restart of the machine can be excluded!



Risk of injury!

Contamination of the mechanism can influence/reduce the stroke, thus the clamping force is reduced and thus, the work piece is not properly tightened and can be thrown out.

- Clean the product regularly [see chapter »Maintenance and service«].



Risk of injury!

If the clamping pressure is too low clamped work piece may be thrown out.

If the clamping pressure is too high severe damages of the components of the clamping device may occur the throwing out of the work piece.

- Before operation set the operation pressure back to operation level.
- The operating pressure should be checked and adjusted regularly!
- The dimension of the work pieces should be checked regularly [clamping- \emptyset]!



Transport!

- For transport always use a suitable clamping means / crane.
- Make sure that a rolling / falling of the clamping device is not possible.



WARNING!

Danger of injury due to vertical suspended spindle!

Bending into the machine work area when assembling overhead can cause severe head injuries.

- Secure components prior to overhead assembly.
- For assembly on a vertically suspended spindle always use a suitable mounting aid.

6.3.1 Assembling the flange [optional]



NOTE!

Material damage due to wrong tightening torque of the cylindrical screws in the spindle flange!

The tightening torque of the cylindrical screws is prescribed by the spindle or machine manufacturer. Incorrect tightening torque of the cylindrical screws in the flange can cause significant material damage on the clamping device and on the machine.

- Only tighten the cylindrical screws of the spindle with the torque prescribed by the spindle or machine manufacturer.

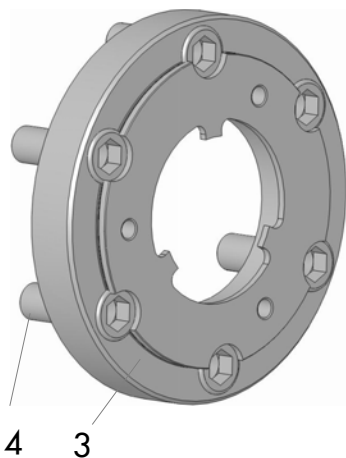

Fig. 16

1. Put the machine in set up mode.
2. Wipe off the mating surfaces of the machine spindle with a soft, lint-free cloth and remove all oil and grease residues.
3. Place the spacer flange on the table with the cylindrical fit facing up.
4. Place the manual chuck with the I.D. fit on the flange.
5. Screw in the mounting screws [4] and tighten them slightly in cross alternation.

6.3.2 Assembly of the TOROK

Two people are required for this task!

Special tools required:

- Allen wrench
- Crane
- Eye bolts

1. Put the machine in set up mode.
2. Remove all tools from the interior of the machine.

Assembly of the TOROK

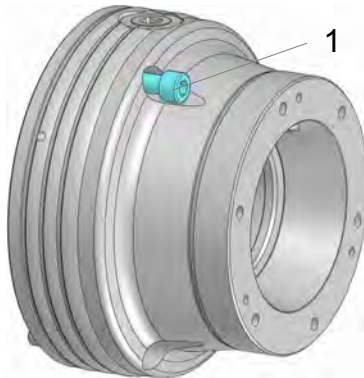

Fig. 17

For the assembly of the TOROK to the machine the following steps are to be done:

- Assemble a spindle flange [optional] onto the machine.
- Place the clamping device onto the machine.
- Screw in the cylindrical screws [1] and tighten them only finger-tight without tightening.

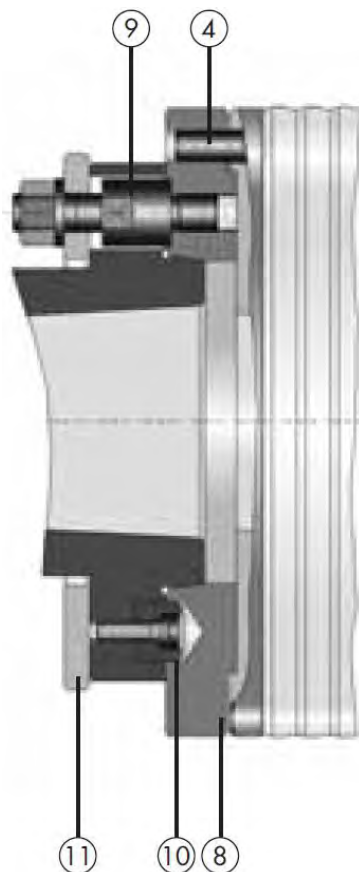

Fig. 18

Assembly of the chuck for the spacer flange with standing bolt

[in accordance with DIN 55027]

1. Place the spacer flange [8] and the chuck on the machine spindle in such a manner that the torsional safety of the spindle engages in the positioning bore [10] in the flange, and so that the camlock bolts [9] of the spacer flange can be inserted in the spindle bores.
2. Turn the bayonet disk [11] on the spindle, counter clockwise on the block as viewed from the machining area of the machine.
3. Place the collar nuts of the stud bolts [9] on the bayonet disk and tighten with fork wrench.

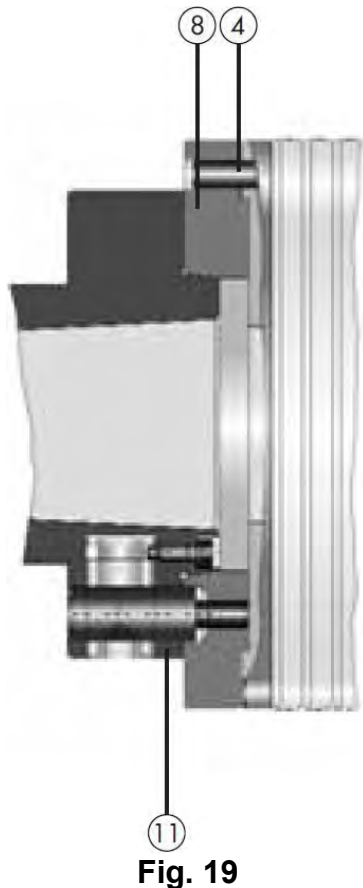

Fig. 19

Assembly of the chuck for the spacer flange with camlock bolt

[in accordance with DIN 55029]

1. Place the spacer flange [8] and the chuck on the machine spindle in such a manner that the torsional safety of the spindle engages in the positioning bore [10] in the flange, and so that the camlock bolts [11] of the spacer flange can be inserted in the spindle bores.
2. Turn each clamping cam clockwise so that the camlock bolts can be tensioned.

6.3.3 Checking and adjusting the face run and the concentricity



NOTE!

Material damage due to insufficient face run and concentricity!

Due to insufficient face run and concentricity work pieces can be damaged during processing.

- After each mounting check, and if necessary readjust, the face run and concentricity of the clamping device.

Checking face run

Special tools required:

- Dial indicator
- Plastic tip hammer

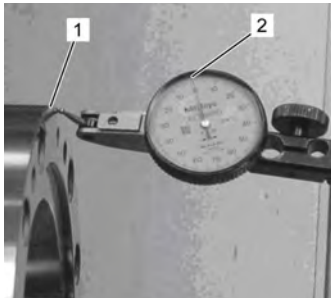

Fig. 20

1. Place the magnetic base of the dial indicator on the inside of the machine.
2. Place the dial indicator for face run on the face of the clamping unit.
3. Use a plastic tip hammer to carefully knock the clamping unit into position.

Checking concentricity

Special tools required:

- Dial indicator
- Plastic tip hammer
- Torque wrench

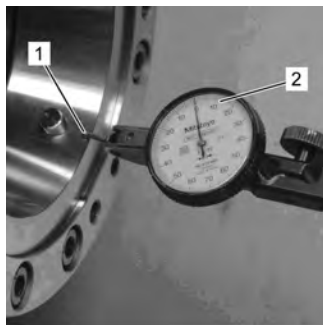

Fig. 21

1. Place the magnetic base of the dial indicator on the inside of the machine.
2. Place the dial indicator for concentricity on the clamping taper.
3. Adjust the clamping device in such a manner that the dial indicator shows the value »0«.



For exact adjustment, if necessary loosen the cylindrical screws several turns and retighten in a cross pattern.

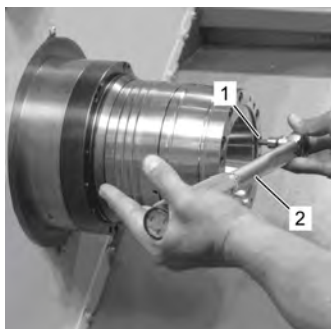

Fig. 22

4. Tighten the cylindrical screws with a torque wrench in a cross pattern [see section »Screw tightening torque«].



For exact adjustment, if necessary loosen the cylindrical screws several turns and retighten in a cross pattern.

5. Wipe off the taper of the the clamping element reception with a soft, lint-free cloth and remove all oil and grease residues.

6.3.4 Assembly of the changing parts

Base end-stop

Special tools required:

- Torque wrench



For assembly and disassembly always disassemble the clamping head from the clamping device!

- Put the base end-stop into the clamping device.
- Screw in the 3 mounting screws and tighten them firmly with the correct tightening torque, see »Maintenance«.

Workpieces may be stopped directly at the surface of the base end-stop, or an additional end-stop may be screwed into the thread of the base end-stop.

Chip guard bushing



When using the clamping device as a through-bore chuck the base end-stop must be disassembled and a chip guard bushing must be assembled.

Special tools required:

- Torque wrench



For assembly and disassembly always disassemble the clamping head and the base end-stop from the clamping device!

- Disassemble the clamping head, see chapter »Assembly / disassembly of the clamping head«.
- Disassemble the base end-stop, see chapter »Disassembly of the changing parts«.
- Push the chip guard bushing into the clamping device.

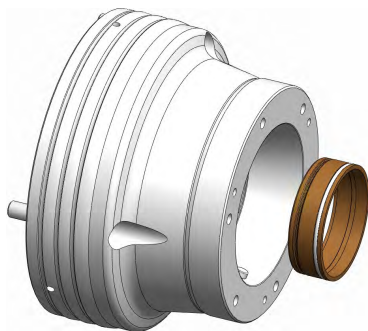

Fig. 23

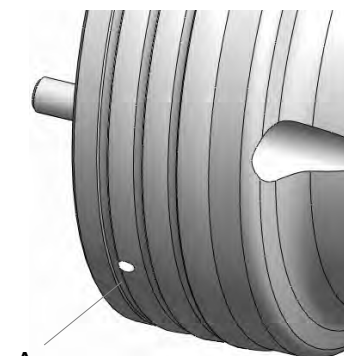

Fig. 24

- Screw in the 3 mounting screws [A] and tighten them firmly with the correct tightening torque, see »Maintenance«.

Front end-stop

Special tools required:

- Torque wrench



Before the assembly of the front end-stop the clamping head for the next machining must be inserted.

- Put the front end-stop on the face of the clamping device.
- Screw in the mounting screws and tighten them firmly with the correct tightening torque, see »Maintenance«.



WARNING!

Risk of injury!

Tools and gages that are thrown out of the machine can cause injury.

- Remove all tools and gages from the working area of the machine before the machine is started up.

6.3.5 Assemble / disassemble the clamping head



For changing in the clamping head move the coupling of the clamping device to front end position.

Depending on the model of the clamping head the handling of the changing fixture is easier or more difficult.

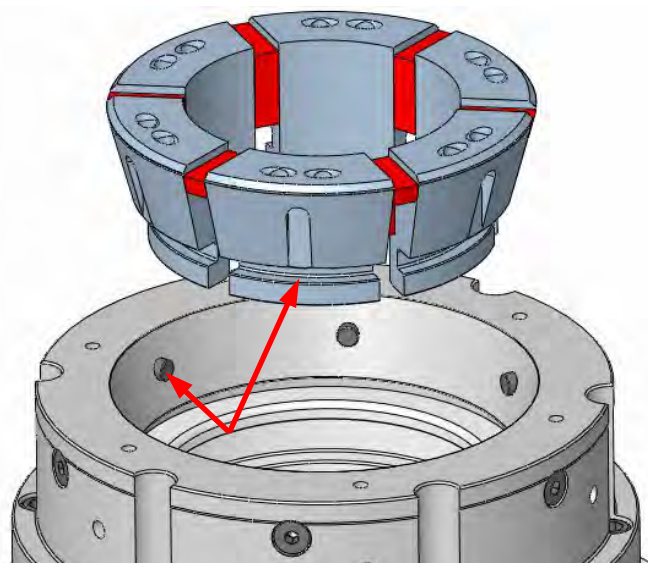

Fig. 25



WARNING!

Danger of violent pressure to hands and fingers!

- During operation never reach into the coupling or slot area of the clamping head nor in the changing fixture.
- Only run the machine in set-up mode or jog mode.
- Before working at the installed clamping device make sure that starting of the machine is impossible.

6.4 Work piece



WARNING!

Risk of injury due to thrown out parts!

During clamping of the work piece and the processing parts can be thrown and cause severe injuries and property damage.

- Check the clamping diameter of the work piece.
- Tighten only work pieces that meet the dimensional requirements.
- For clamping very long work pieces use in addition a tailstock / a steady rest for support.
- Do not exceed the maximum clamping pressure.
- Make sure that the correct supply pressure [neither too high nor too low] is set.



CAUTION

Risk of injury!

When placing the work piece:

- Make sure that the hands / fingers may not be clamped between the flange and the work piece!

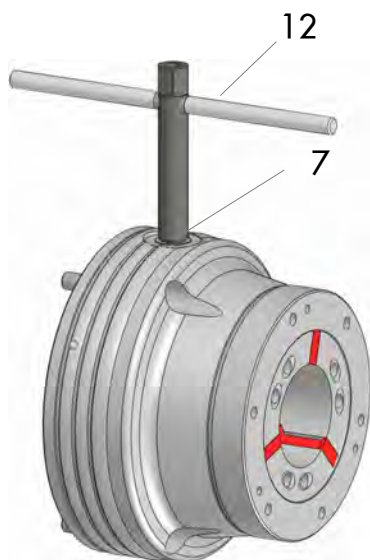

Fig. 26

Special tools required:

- Actuating wrench

After assembling the clamping head a work piece may be clamped in the chuck.



The safety ring must be present and in correct position!

- For clamping turn the actuating screw [7] clockwise by using the actuating wrench [12].



In order to ensure consistent clamping, we recommend to tighten the actuating screw [7] the use of a torque wrench set [optional] SW17.

- Tighten the actuating screw [7] firmly.



Risk of injury!

Tools and measuring equipment may spin out.

- Remove all tools and measuring equipment before machining from the machine!
- When working with a hand chuck always use a protective cover for protection from flying chips.
- The use of eye protection is mandatory.

Remark for the work piece:

- Work pieces may not be too out of round.
- The minimum clamping depth of 3.0 mm usually may not be exceeded!

When exceeding, contact the manufacturer!

To release the clamping pressure, turn the actuation screw [7] anti-clockwise by using the actuating key [12]. Hold the work piece firmly to prevent it from falling off the chuck.



WARNING!

Risk of injury due to spinning out tools and/or measuring equipment!

When the chuck will be set into rotation, the actuating key [12] may never stuck in the chuck!

- The actuating key [12] is provided with a spring that pushes the key out of the chuck as soon as it is released.
- If the spring is damaged or the function may be impaired or missing, insert a functional spring into the key before using it again!

6.4.1 Add on clamping element MANDO Adapt



Fig. 27

Changing from outside to inside clamping without taking the chuck off the machine? No problem with MANDO Adapt: Place the mandrel on the SPANNTOP chuck, tighten the three screws, screw in the draw bolt to actuate the segmented bushings – and an ingenious mechanism adapts to the coupling that normally grips the clamping head. That's all there is to it!

You save a considerable amount of time and the MANDO Adapt delivers superb rigidity and precision as an added bonus. It results in a concentricity of less than 0.005 mm from the mandrel body to the chuck taper.

Simple and effective

- Quick change-over from outside to inside clamping
- Concentricity < 0.005 mm [for chuck taper]
- Available in five different mandrel sizes for each of the chuck sizes 42–100

For further information read the installation manual of the MANDO Adapt!

6.4.2 Add on clamping element jaw module



Fig. 28

Small clamping diameter - small chuck

This is the simple formula of our new modular solution. Because with the new small jaw module already 80% of the components are usually covered and for large components it can easily be converted within just 30 seconds on a large.

The base unit is a SPANNTOP or TOPlus chuck.

The facts:

- small interfering contour, optimum utilization of the jaws
- flexible, fast and repeatable set-up on the clamping head clamping or mandrel clamping
- dead-length clamping with clamping jaws [e.g. hard jaws on the blank]
- ideal for sensitively clamping and filigree components
- also very suitable for stationary use

Read the installation instructions in the manual for the module jaw!

6.5 Inspections



NOTE!

Material damage due to damaged clamping devices!

A damaged, incomplete, or unbalanced clamping device or adapter can significantly damage or even destroy the machine tool and the work piece.

- Only install undamaged, complete, and precisely balanced products.
- If in doubt contact the manufacturer.

Ensure the following points prior to each installation and start-up of the product:

- All cylindrical screws of the product must be present and tightened with the proper tightening torque.
- The balance screws [if required] must all be present and undamaged.
- All rubber segments must be intact; this means that they are neither torn, nor are they porous at any point.
- All edges and bearing surfaces are intact; this means that they are neither broken nor do they show any signs of wear.
- The set speed of the machine tool should not exceed the maximum permissible speed of the product.
- The maximum draw tube force specified on the perimeter of the product must not be exceeded.
- All mounting tools must be removed from the interior of the machine.
- Clamping device and work piece must be compatible –check the clamping diameter regularly.
- The work piece must be clamped with sufficient work piece tension.
- Do a pressure loss test and a measurement of clamping force.

6.6 Control of the stroke position



WARNING!

Crushing danger from moving parts!

Crushing danger from moving parts during controlling the stroke position!

Gaps, caused while controlling the stroke position, can cause severe injury.

- Only do the controlling of the stroke position with assembled changing parts.
- Only run the machine in set-up mode or jog mode.
- Do not reach into moving parts or handle moving parts during operation.
- Note the gap dimensions of moving parts.
- Wearing of gloves / [PSA] is required!

6.7 Activities after production is concluded

1. Move the clamping device into unclamped position.
2. Switch off the machine tool and safeguard it from being switched on again.
3. Open the protective door or hood.
4. Clean the clamping device and a possibly mounted adaptation clamping device and adapter of chips and production residues using a soft, lint-free cloth and oil them lightly.
5. Close the protective door or hood.

7 Disassembly

If there is break in production that lasts longer than 3 days, the clamping device must be disassembled and properly stored in accordance with the manufacturer's specifications [see section »Transport, packaging, storage«].

Prior to disassembling:

- Put the machine in set up mode.
- Remove fuels and auxiliary materials, as well as residual processing materials and dispose of these items in an environmentally-responsible manner.

7.1 Safety

Safeguarding against restart



DANGER!

Life-threatening danger if restarted without authorization

When disassembling there is danger of the energy supply being switched on inadvertently. This poses a life-threatening hazard for persons in the danger zone.

- Prior to starting the tasks switch off all energy supplies and safeguard them from being switched on again.



WARNING!

Danger of injury due to falling components!

When mounting components can fall and cause severe injury and material damage.

- Two people are always required for this task.
- Use a crane.
- For assembly on a vertically suspended spindle always use a suitable mounting aid.



WARNING!

Danger of injury due to vertical suspended spindle!

Bending into the machine work area when assembling overhead can cause severe head injuries.

- Secure components prior to overhead assembly.
- For assembly on a vertically suspended spindle always use a suitable mounting aid.



Transport!

- For transport always use a suitable clamping means / crane.
- Make sure that a rolling / falling of the clamping device is not possible.

7.2 Disassembling the clamping device

7.2.1 Disassembling the changing parts

Front end-stop

Special tools required:

- Allen wrench

Disassembly:

- Loosen and remove the mounting screws.
- Remove the front end-stop from the surface.

Chip guard bushing

Special tools required:

- Allen wrench



For the disassembly the clamping head must always be removed from the clamping device!

- Disassemble the clamping head, see chapter »Assembly / disassembly of the clamping head«.
- Loosen the 3 mounting screws.
- Remove the chip guard bushing to the front side out of the clamping device.

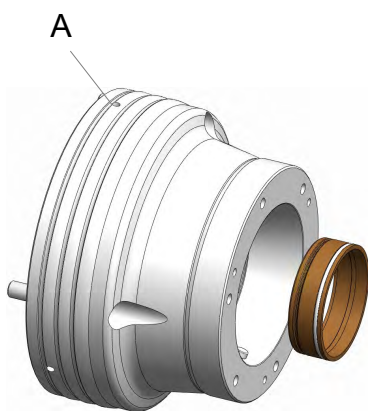

Fig. 29

Base end-stop

Special tools required:

- Allen wrench



For the assembly and disassembly the clamping head must always be removed from the clamping device!

- Loosen the 4 mounting screws.
- Remove the base end-stop from the clamping device.

7.2.2 Disassembly of the TOROK

Two people are required for this task!

Special tools required:

- Allen wrench
- Crane
- Eye bolts

1. Put the machine in set up mode.
2. Remove all tools from the interior of the machine.

Disassembly of the TOROK

For the disassembly of the TOROK from the machine the following steps are to be done:

- Secure the clamping device at the eye bolts by a crane.
- Loosen and remove the cylindrical screws [1].
- Remove the clamping device from the machine and place it safely.

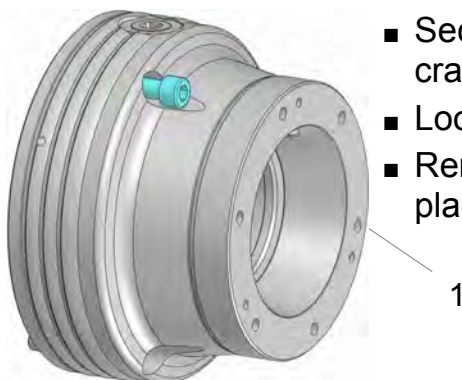

Fig. 30

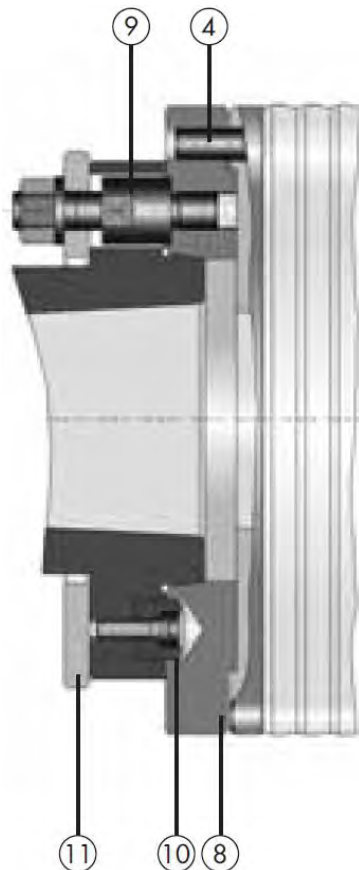

Fig. 31

Disassembly of the chuck from a spacer flange with standing bolt

[in accordance with DIN 55027]



Risk of injury!

Screw in the eye bolts before disassembly.

1. Loosen and remove all cylindrical screws by using an allen wrench.
2. Loosen the collar nuts of the stud bolts [9] on the bayonet disk.
3. Turn the bayonet disk [11] on the spindle, anti-clockwise on the block as viewed from the machining area of the machine.
4. Remove the spacer flange [8] and the chuck from the machine spindle.

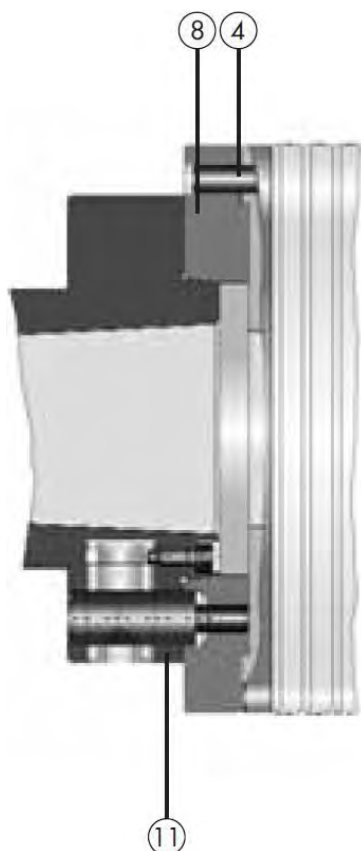

Fig. 32

Disassembly of the chuck from the spacer flange with camlock bolt

[in accordance with DIN 55029]



Risk of injury!

Screw in the eye bolts before disassembly.

1. Loosen and remove all cylindrical screws by using an allen wrench.
2. Turn each clamping cam anti-clockwise so that the camlock bolts can be tensioned.
3. Remove the spacer flange [8] and the chuck from the machine spindle.

7.2.3 Disassembling the flange [optional]

The task requires two people.

Special tools required:

- Allen wrench

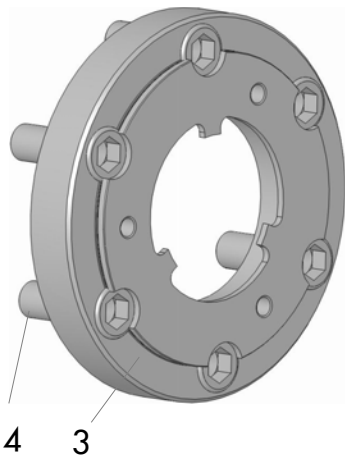

Fig. 33

1. Put the machine in set up mode.
2. Wipe off the mating surfaces of the machine spindle with a soft, lint-free cloth and remove all oil and grease residues.
3. Deposit the clamping device with the flange down.
4. Loosen and remove the mounting screws [4].
5. Take the clamping device from the flange.



NOTE!

Damage due to contaminated and/or damaged bearing surfaces.

- Check the two bearing surfaces for damages, replace them if necessary.
- Clean the two bearing surfaces from contamination.

7.3 Subsequent storage of the clamping device

The clamping device must be cleaned and treated with corrosion protection for subsequent storage [see section »Cleaning«].



NOTE!

The storage conditions are specified in the section »Transport, packaging and storage«.

7.4 Disposal

If a return or disposal agreement has not been concluded, then recycle disassembled components.



NOTE!

Improper disposal causes environmental damage!

Lubricants and other auxiliary materials are subject to treatment as special waste, and should only be disposed of by approved specialist companies!



NOTE!

Composite materials!

For disposal clamping devices which include composite materials [mineral cast, CFK] must be returned at HAINBUCH!

Local municipal authorities or specialized disposal companies provide information on environmentally-responsible disposal.

8 Maintenance

Environmental protection

Comply with the following instructions for environmental protection when performing maintenance work:

- At all lubricating points where lubricant is applied by hand, remove escaping, used, or excess grease, and dispose of it in accordance with applicable local regulations.
- Collect used oil in suitable containers and dispose of it in accordance with applicable local regulations.

8.1 General

Cleanliness of the appropriate end-stop as well as the guidance diameters are conditions for reaching the concentricity and perpendicularity tolerances. Clean these surfaces with an appropriate cleaner.



CAUTION

Danger of injury due to improper handling of cleaners!

Improper handling of cleaners can cause health impairments.

- Always comply with the safety data sheets and guidelines provided by the manufacturer of the cleaning agent for handling/using the cleaners.



CAUTION

Danger of injury due to loss of clamping force!

Fouling of the clamping device can cause the clamping device to lose considerable clamping force.

- Always comply with the maintenance and cleaning intervals specified in this manual.
- In conjunction with the maintenance intervals, regularly check the maintenance status of the clamping device through clamping force measurements.



Risk of injury!

Slipping while the lubricating with a grease gun can lead to severe cuts!

8.2 Cleaning



NOTE!

Material damage if cleaned with compressed air!

Cleaning the clamping device with compressed air can force metal chips into thread and grooves. This can damage or even destroy the clamping device.

- Never clean the clamping device with compressed air!



Fig. 34

- Auxiliary material required:
 - Ester-free, non-polar cleaning agent
 - Soft, lint-free cloth
- 1. Disassemble the clamping device [see section »Disassembling the TOROK«].
- 2. Clean all the components listed below with cleaning agent and a cloth; remove all oil and grease residues:
 - Flange
 - Clamping device
 - Clamping element reception and coupling area
 - Cylindrical screws



Risk of injury due to wrong assembly!

A wrong assembled safety ring may cause throwing out of parts.

- The safety ring at the actuating screw [square] must be completely inserted into the groove!

8.3 Preservation

- Special tools required:
 - Universal grease 2085/0003
 - Grease gun
 - Oil stone
 - Soft, lint-free cloth



Fig. 35

1. Hone all the bearing surfaces of the clamping device with an oil stone.
2. Lightly grease all cylindrical screws. Remove excess grease with a cloth.
3. Screw all cylindrical screws into the clamping device again and tighten them hand tight.



For subsequent storage tightening the cylindrical screws hand tight suffices. This facilitates re-commissioning and protects the cylindrical screws.

4. Lightly grease all interior and outer surfaces of the clamping device. Remove excess grease with a cloth.
5. Pack the clamping device airtight in foil. Place it on a level, impact-free storage location and safeguard it from falling.

8.4 Use of lubricant

With the usage of lubricant you may only use grease that corresponds to the requirements concerning bond, pressure-stability and solubility in lubricating coolant. In addition no dirt particles may be in the grease; they cause run errors if they come in in-between two mating surfaces.

We recommend for this the following lubricant:

HAINBUCH grease

See »Optional accessories«

Alternatives:

Lubricant	Manufacturer	Product
Universal grease	OKS	OKS 265
	MicroGleit	GP 355
	Klüber	QNB 50
	Zeller & Gmelin	DIVINOL SD24440
	Bremer & Leguill	RIVOLTA W.A.P.
Special grease	Klüber	MICROLUBE GL 261

To ensure proper function, we recommend – in addition to the weekly lubrication interval – to disassemble the chuck body once a month from the spindle flange.



Lubricants are not contained in the scope of delivery!

8.4.1 Lubrication

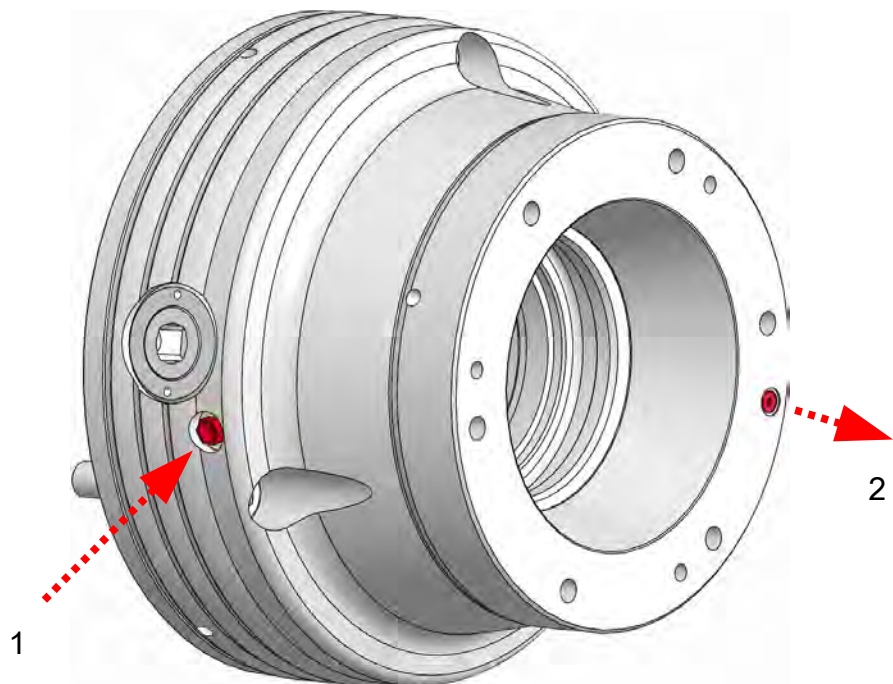

Fig. 36

The clamping device may be equipped with lubrication nipples.

For lubricating the clamping device by the lubrication nipples the following steps are required:

- Disassemble the changing parts.
- Disassemble the add on clamping element.
- Move the coupling into rear end position.
- Press in the grease by the laterally lubrication nipple [1] until the grease comes out at the front relief valve [2].
- Move the clamping device twice into end position in order to achieve a good distribution of the grease.

8.4.2 Lubrication interval

The lubrication occurs always with maintenance and additionally as required.

8.5 Maintenance schedule

Maintenance tasks are described in the sections above that are required for optimal and trouble-free operation.

If increased wear is detected during regular inspections, then reduce the required maintenance intervals according to the actual indications of wear.

Contact the manufacturer, [see the service address on the back] if you have questions concerning maintenance tasks and intervals.

Interval	Maintenance task
Daily	Visual check, especially at the clamping and bearing surfaces, to determine damages at the clamping device and at the vulcanization of the clamping elements early. With heavy contamination complete cleaning [see chapter »Cleaning«].
Every 36 operating hours	Clean the clamping unit [see section »Cleaning«]
	Clean the taper reception and coupling area [see section »Cleaning«]
	Grease the clamping unit [see section »Preservation«]
If necessary	Manufacturer service



For proper operation of the coolant feed a pre-filtering with duplex filter (mesh size 100 µm, PI 3754) is necessary. The duplex filter is mounted on the coolant cleaning system.

8.6 Bolt torque

Metric ISO thread

The guide values for bolt tightening torque for achieving the highest permissible pre-tension for metric ISO thread are specified in Nm in the table.

- Total friction coefficient $\mu_{\text{tot}} = 0,12$

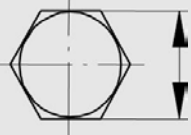
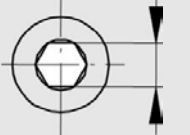
Diameter	 [mm]	 [mm]	Torque for screw quality 10.9 [Nm]
M 4	7	3	4
M 5	8	4	7
M 6	10	5	12
M 8	13	6	25
M 10	17	8	50
M 12	19	10	100
M 16	24	14	220
M 20	30	17	400
M 24	36	19	600

The table shows the prescribed values.

Knowledge of the applicable guidelines and configuration criteria are the prerequisites.

9 Trouble shooting

Possible fault causes and the tasks to correct these faults are described in the following section.

If faults occur more frequently, the maintenance intervals must be shortened to correspond to the actual system load.

Contact the manufacturer if there are faults that cannot be corrected by following the instructions below; see the service address on the back of this operating instruction.

9.1 Safety

Trouble shooting

The following always applies:

1. For faults that pose a direct danger for personnel and or property immediately execute the emergency-stop function of the machine.
2. Determine the cause of the fault.
3. If correction of the fault requires work in the danger zone, put the machine in set-up mode.
4. Immediately inform the responsible parties at the installation site of the fault.
5. Depending on the type of fault, either have authorized specialized personnel correct the fault, or correct it yourself.



The trouble shooting table provided below lists personnel who are authorized to correct the fault.

6. If there is a fault that was not caused by the clamping device the cause of the fault may be in the machine area. See the operating manual for the machine in this regard.

9.2 Trouble shooting table

Fault	Possible cause	Fault correction	Corrected by
Clamping head cannot be replaced	The change gap between the clamping head coupling and work piece end-stop is insufficient.	Rework the work piece end-stop	Specialist
Clamping device does not open or the release stroke is insufficient.	Fouling between the draw mechanism and the clamping unit	Remove the clamping head, move the drawtube back and clean the coupling area [see section »Disassembling the clamping head«].	Specialist
Clamping force is too low	Work piece is under-dimensioned	Replace with a suitable clamping head	Specialist
	Excessive mechanical friction	Check idle moment [3-5 Nm]	Hydraulic specialist
	Defective clamping cylinder or blocked drawtube	Contact the machine manufacturer	Machine manufacturer
	Compression springs fatigued [at permanent tension]	Replace compression springs	Specialist
Eccentric dimensional deviation on the work piece	Concentricity error of the clamping unit	Check the concentricity on the clamping taper and correct it if necessary [see section »Checking and adjusting the face run and concentricity of the clamping unit«].	Specialist
Dimensional deviation on the work piece	Contaminated coupling area	Clean the coupling area of the clamping unit [see section »Cleaning«].	Specialist
	Contaminated clamping taper	Remove the clamping head and clean the clamping taper [see section »Cleaning«].	Specialist
Formal defect on the work piece	Elastic deformation of feedstock that is subject to formal defects. After machining, the work piece returns to its original form.	Use feedstock with fewer formal defects. Use a clamping head with several sharp teeth in the clamping surface.	Specialist

Fault	Possible cause	Fault correction	Corrected by
Marks on the clamping surface	Point or linear work piece clamping	Replace with a clamping head that has a smoother clamping surface	Specialist
	Wrong clamping head type	Replace the clamping head	Specialist
	Excessive dimensional difference between the work piece diameter and the clamping bore	Replace with a clamping head that has a suitable clamping bore	Specialist

9.3 Start-up after corrected fault

After correcting the fault execute the following steps to start up again:

1. Reset the emergency-stop device
2. Acknowledge the fault on the machine tool controller
3. Ensure that no one is in the danger zone
4. Start the machine tool

10 Appendix

10.1 Service Hotline

Order Hotline

Quickly ordered and delivered. A call is all it takes:
+49 7144. 907-333

Schedule Hotline

Current status of your order? Just call:
+49 7144. 907-222

24h emergency call

Has there been a crash or other technical emergency?

Our experts are at your service around the clock:
+49 7144. 907-444

10.2 Representatives

The sales partners and service employees listed below are available for further consultation or support.

10.2.1 Europe

Austria

HAINBUCH in Austria GmbH
SPANNENDE TECHNIK
Pillweinstr. 16
5020 Salzburg
Phone +43 662 825309
E-mail: verkauf@hainbuch.at
Internet: www.hainbuch.com

Belgium

BIS Technics bvba/sprl
Zevenputtenstraat 20
3690 Zutendaal
Phone +32 89518890
Fax +32 89518899
E-mail: info@bistechnics.com
Internet: www.bistechnics.com

Denmark

Jørn B. Herringe A/S
Ramsømagle
Syvvejen 31
4621 Gadstrup
Phone +45 46170000
Fax +45 46170001
E-mail: sales@jbh-tools.dk
Internet: www.jbh-tools.dk

Austria

GGW Gruber & Co. GmbH
Kolingasse 6
1090 Vienna
Phone +43 13107596-0
Fax +43 13107596-31
E-Mail: office@ggwgruber.com
Internet: www.ggwgruber.com

Czech Republic,

TMC CR s.r.o.
Masná 27/9
60200 Brno
Phone +420 533433722
Fax +420 548217219
E-mail: info@tmccr.cz
Internet: www.tmccr.cz

Estonia, Latvia, Lithuania

DV-Tools OÜ
Peterburi tee 34/4
11415 Tallinn
Phone +372 6030508
Fax +372 6030508
E-mail: info@dv-tools.ee
Internet: www.dv-tools.ee

Finland

Oy Maanterä Ab
PL 70 Keinumäenkuja 2
01510 Vantaa
Phone +358 29006130
Fax +358 290061130
E-mail: maantera@maantera.fi
Internet: www.maantera.fi

France

Representative for: Haute Savoie

Utilis France Sarl
597, Avenue du Mont Blanc
74460 Marnaz
Phone +33 450963630
Fax +33 450963793
E-mail: contact@utilis.com
Internet: www.utilis.com

Greece

PAPET Papadopoulos GbR
Martinstrasse 68
DE-73061 Ebersbach/Fils
Phone +49 71635858/530668
Fax +49 716352265
E-mail: paris@papet-technologies.de

Ireland

HAINBUCH UK Ltd.
WORKHOLDING TECHNOLOGY
6 Newmarket
Keys Business Village, Keys Park Road
Hednesford, Staffordshire
WS12 2HA
Phone +44 1543 278731
Fax +44 1543 478711
Mobile +44 7980212784
E-mail: nick.peter@hainbuch.co.uk
Internet: www.hainbuch.com

Netherlands

BIS Specials
[Brandenburg Industry Service Dongen BV]
Dreef 7
6996 BA Drempt
Phone +31 313482566
Fax +31 313482569
E-mail: info@bisspecials.com
Internet: www.bisspecials.com

France

HAINBUCH France SNC
Equipements de machines-outils
ZI Lons-Perrigny
1600, Route de la Lième
39570 Lons-le-Saunier
Phone +33 384876666
Fax +33 384876677
E-mail: info@hainbuch.fr
Internet: www.hainbuch.com

Great Britain

HAINBUCH UK Ltd.
WORKHOLDING TECHNOLOGY
6 Newmarket
Keys Business Village, Keys Park Road
Hednesford, Staffordshire
WS12 2HA
Phone +44 1543 278731
Fax +44 1543 478711
Mobile +44 7980212784
E-mail: nick.peter@hainbuch.co.uk
Internet: www.hainbuch.com

Hungary

GIMEX Hydraulik GmbH
Selyem utca 1.
9025 Györ
Phone +36 96525588
Fax +36 96427239
E-mail: info@gimex.hu
Internet: www.gimex.hut

Italy

HAINBUCH Italia srl
Via Caduti di Nassiriya 5
22036 Cantu [Co]
Phone +39 0313355351
Fax +39 031611570
E-mail: info@hainbuchitalia.it
Internet: www.hainbuchitalia.it

Norway

Onstad Maskin A/S
Chr. H. Blomsgt. 13
3717 Skien
Phone +47 35532373/74
Fax +47 35532375
E-mail: postmaster@onstadmaskin.no
Internet: www.onstadmaskin.no

Poland

BIM Sp. z o.o.
Złotniki, ul. Kobaltowa 6
62-002 Suchy Las
Phone +48 616232041
Fax +48 616232040
E-mail: bim@bazafirm.pl

Russia

ROSNA Engineering LLC
Sveaborgskaya street, 12, Letter »A«, office
20N,
196105 Saint-Petersburg
Phone +7 812 4016767
Fax +7 812 4016767
E-mail: rosna@rosna.spb.ru
Internet: www.rosna.spb.ru

Slovenia

Elmetool d.o.o.
Prvomajska ulica 62
5000 Nova Gorica
Phone +386 53303300
Fax +386 53303304
E-mail: info@elmetool.si

Sweden

HAINBUCH Svenska AB
SPÄNNANDE TEKNIK
Kemistvägen 17
18379 Täby
Phone +46 87327550
Fax +46 87327650
E-mail: hainbuch@hainbuch.se
Internet: www.hainbuch.com

Turkey

Hidkom
Organize Sanayi Bölgesi
75. Yil CD. Demirciler Sit. B Blok No.2
16159 Nilüfer / Bursa
Phone +90 2242438292
Fax +90 2242436365
E-mail: hidkom@tr.net
Internet: www.hidkom.com

Romania

Banatech srl. – connecting technologies
Ep. Miron Cristea 26
325400 Caransebes, Caras Severin
Phone +40 255517175
Fax +40 355814125
Mobile +40 749220553
E-mail: office@banatech.ro
Internet: www.banatech.ro

Slovakia

NS s.r.o.
Vácka ulica 4109/10
01841 Dubnica N/V
Phone +421 424450873
Fax +421 424440406
E-mail: tns@tnssro.sk
Internet: www.tnssro.eu

Spain, Portugal

ATM S.L
C/. Gran Bretanya, 16
Pol. Ind. Pla de Llerona
08520 Les Franqueses del Vallès
[Barcelona]
Phone +34 938700885
Fax +34 938791689
E-mail: atm.sl@atmbarcelona.com

Switzerland

Utilis Müllheim AG
Präzisionswerkzeuge
Kreuzlinger Strasse 22
CH-8555 Müllheim
Phone +41 527626262
Fax +41 527626200
E-mail: info@utilis.com
Internet: www.utilis.com

10.2.2 America

Argentina

HAINBUCH America Corp.
WORKHOLDING TECHNOLOGY
W129N10980 Washington Dr.
Germantown, WI 53022
U.S.A
Phone +1 4143589550
Fax +1 4143589560
E-mail: sales@hainbuchamerica.com
Internet: www.hainbuchamerica.com

Canada

HAINBUCH America Corp.
WORKHOLDING TECHNOLOGY
W129 N10980 Washington Dr.
Germantown, WI 53022
U.S.A
Phone +1 4143589550
Fax +1 4143589560
E-mail: sales@hainbuchamerica.com
Internet: www.hainbuch.com

Mexico

HAINBUCH America Corp.
WORKHOLDING TECHNOLOGY
W129 N10980 Washington Dr.
Germantown, WI 53022
Phone +1 4143589550
Fax +1 4143589560
E-mail: sales@hainbuchamerica.com
Internet: www.hainbuch.com

Brasil

SSanposs Tecnologia
Suprimentos e Consultoria Internacional Ltda.
Rua Cândia nº 65 - Jardim do Mar
CEP: 09726-220
São Bernardo do Campo - São Paulo
Phone +55 11 41266711
Fax +55 11 41266710
E-mail: tsci@sanposs.com.br
Internet: www.sanposs.com.br

Canada

Representative for: Ontario, Québec
J.Winkel & Associates Inc.
6516 Warbler Lane
L5N 6E1 Mississauga, Ontario
U.S.A
Phone +1 4143589550
Fax + 1 4143589560
E-mail: sales@hainbuchamerica.com
Internet: www.hainbuch.com

USA

HAINBUCH America Corp.
WORKHOLDING TECHNOLOGY
W129 N10980 Washington Dr.
Germantown, WI 53022
Phone +1 4143589550
Fax +1 4143589560
Se habla español:
Tel +1 2143268081
E-mail: sales@hainbuchamerica.com
Internet: www.hainbuch.com

10.2.3 Asia

China

HAINBUCH Shanghai Co. Ltd.
WORKHOLDING TECHNOLOGY
Room 611-612 BaoHong Center
No. 7755 Zhongchun Road
Minhang District, Shanghai 201101
Phone +86 2120916384
Fax +86 2120916383
E-mail: sales@hainbuch.cn
Internet: www.hainbuch.cn

India

A.H. Rao
Technical Consultant to HAINBUCH
Ground Floor, # 4157, 14th Main
HAL 2nd Stage, Indiranagar
Bangalore 560 008
Phone +91 8041463972
Mobile +91 9986997959
E-Mail: ahr.rao@gmail.com

India

M'la Sales Corporation
5, Yeshwantnagar
Telco-Century Enka Road
Pimpri, Pune 411018
Phone +91 20 27477405
Fax +91 20 27464249
E-mail: info@m-la-sales.com
Internet: www.m-la-sales.com

Indonesia

PT. STAHL ARBEIT
WTC Mangga Dua 2nd Floor A-6
JL. Mangga Dua Raya No. 8
Level 2 Blok C No. 41-45
Jakarta 14430
Phone +62 21 3777 6622
Fax. +62 21 3001 8070
E-mail: info@stahl-arbeit.com
Internet: www.stahl-arbeit.com

Israel

M.T.M. Machine Tools Marketing Ltd.
26 Hakishor St.
Holon 58867
Phone +972 36479560
Fax +972 36479578
E-mail: sales@mtm.co.il
Internet: www.mtm.co.il

Korea

Kimi Co.
B-101 98 Okgucheondongro Siheung-Si
429-925 Gyeonggi-Do
Phone +82 24137911
Fax +82 24137910
E-Mail: kimi@kimigroup.co.kr

Taiwan

GSTC Technology Co., Ltd.
No. 418, Youn-Chun East 1st Rd
Taichung City 40877, Taiwan'
Phone +88 6423805678
Fax +88 6423805511
E-mail: gstc@seed.net.tw
Internet: www.gstctech.com.tw

Japan

NK Works Co LTD
2-17-17 Iwamoto-cho, Chiyoda-ku
Tokyo, 101-0032
Phone +81 338645411
Fax +81 338646752
E-mail: info@nk-works.co.jp
Internet: www.nk-works.co.jp

Malaysia, Singapore & Vietnam

Jebsen & Jessen Technology [S] Pte Ltd.
Process Engineering Division
18 Enterprise Road
Singapore 629824
Phone +65 63053692
Fax +65 63053699
E-mail: phillip_lee@jjsea.com
Internet: www.jjsea.com

Thailand

HAINBUCH [Thailand] Co. Ltd
WORKHOLDING SOLUTIONS
2/25 Sukhapiban 2 Road Prawet,
Prawet, Bangkok 10250
Phone +662329 0622/23
Fax +662329 0624
E-Mail: info@hainbuch.co.th
Internet: www.hainbuch.com

10.2.4 Australia

Australia

Romheld Automation Pty Ltd
Unit 30 115 Woodpark Road
Smithfield . NSW. 2164
Phone +61 297211799
Fax +61 297211766
E-mail: sales@romheld.com.au
Internet: www.romheld.com.au

10.2.5 Africa

South Africa

South Africa Retecon [PTY] Ltd.
P.O. Box 1472
1620 Kempton Park
Phone +27 119768600
Fax +27 113942471
E-mail: tools@retecon.co.za
Internet: www.retecon.co.za

Index

A

Accessories.....	
Chip guard bushing.....	24
Clamping head.....	23
Grease.....	25
Grease gun.....	25
Key.....	25
optional.....	23
Torque wrench set.....	25
Work piece end-stop.....	24

Assembly.....	
Add on clamping element - jaw mod- ule.....	42
Add on clamping element - MANDO Adapt.....	42
Clamping head.....	39
Concentricity and face run.....	36
Flange.....	34
TOROK.....	34
Work piece.....	40

B

Bolt torque.....	56
Brief description.....	22

C

Carbon / CFK.....	7
Changing fixture.....	
Manual.....	24
pneumatic.....	24

Check.....	21
Cleaning.....	52
Control of the stroke position.....	44

D

Disassembly.....	
Clamping head.....	39
Flange.....	49
TOROK.....	47

Disposal.....	50
---------------	----

E

Environmental protection.....	17
-------------------------------	----

I

Inspections.....	43
Installation.....	
Preparations.....	31
Intended use.....	9

L

Loads.....	12
------------	----

M

Maintenance schedule.....	55
Misuse.....	10

O

Operating conditions.....	21
Overview.....	22

P

Packaging.....	28
Personal protective equipment.....	
Hard hat.....	11
Protective gloves.....	11
Protective goggles.....	11
Protective work clothing.....	11
Safety footwear.....	11
Personnel requirements.....	8
Power specifications.....	21
Preservation.....	52

R

Representatives.....	
Africa.....	64
America.....	63
Asia.....	63
Australia.....	64
Europe.....	60

S

Scope of delivery.....	7
Spare parts.....	7
Special dangers.....	11
Storing.....	29
Structure.....	22
Symbols on the packaging.....	26

T

Transport inspection.....	27
Transport, inner company.....	27
Trouble shooting.....	57
Trouble shooting table.....	58
Type designation.....	21

U

Unpacking.....	27
Use.....	9

EC Declaration of conformity

EG-Konformitätserklärung im Sinne der EG-Richtlinie 2006/42/EG über Maschinen [Anhang II A] /

EC Declaration of conformity according to EC directive 2006/42/EC on machinery [Annex II A]

Original-Konformitätserklärung / Translation of original declaration of conformity

Hersteller / manufacturer: HAINBUCH GmbH Spannende Technik
Erdmannhäuser Straße 57
71672 Marbach
Deutschland

Diese Erklärung bezieht sich nur auf die Maschine in dem Zustand, in dem sie in Verkehr gebracht wurde; vom Endnutzer nachträglich angebrachte Teile und/oder nachträglich vorgenommene Eingriffe bleiben unberücksichtigt. Die Erklärung verliert ihre Gültigkeit, wenn das Produkt ohne Zustimmung umgebaut oder verändert wird.

This declaration relates exclusively to the machinery in the state in which it was placed on the market, and excludes components which are added and/or operations carried out subsequently by the final user. The declaration is no more valid, if the product is modified without agreement.

Hiermit erklären wir, dass die nachstehend beschriebene Maschine
Herewith we declare, that the machinery described below

Produktbezeichnung / product denomination: TOROK

allen einschlägigen Bestimmungen der Maschinenrichtlinie 2006/42/EG entspricht.
is complying with all essential requirements of the Machinery Directive 2006/42/EC.

Angewandte harmonisierte Normen / Harmonised Standards used:

- EN ISO 12100:2011-03 Sicherheit von Maschinen – Allgemeine Gestaltungsgrundsätze
Safety of Machinery – Basic concepts
- DIN EN 1550:1997 Sicherheitsanforderungen für die Gestaltung und Konstruktion von Spannfuttern für die Werkstückaufnahme /
Safety requirements for the design and construction of work holding chucks

Bevollmächtigter für die Zusammenstellung der technischen Unterlagen /
The person authorized to compile the relevant technical documentation:
HAINBUCH GmbH Spannende Technik
Konstruktionsleitung
Erdmannhäuser Straße 57
71672 Marbach
Deutschland

Marbach, 01 July 2015

Konstruktionsleitung / Head of engineering

Ort, Datum /
Place, Date

Funktion / function of signatory



HAINBUCH GMBH · SPANNENDE TECHNIK
PO Box 1262 · 71667 Marbach / Erdmannhauser Strasse 57 · 71672 Marbach · Germany
Phone +49 7144.907-0 · Fax +49 7144.18826 · sales@hainbuch.de · www.hainbuch.com
24h-Emergency call +49 7144.907-444