

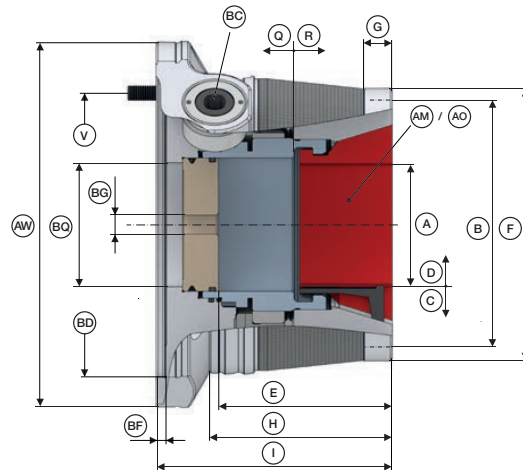

STANDARD CHUCKS

Manual chuck TOROK

TOROK CFK SE. Technical data



Product line	SE	
Size	52	65
Concentricity [mm]	0,015	
Max. radial clamping force [kN]	108	120
Max. axial drawtube force [kN]	40	45
Flange location	BD	Ø 145 H7
Flange fit length [mm]	BF	5,1
Max. actuating torque [Nm]	BC	57
RPM n max. [1/min.]		7000
Clamping range [mm]	A	4 – 52
Release stroke in Ø [mm]	C	0,6
Reserve stroke in Ø [mm]	D	1
Range / recommended workpiece tolerance [mm]	± 0,5	
End-stop depth [mm]	E	90
Ø Capacity [mm]	BQ	53
End-stop thread size [M]	BG	10
Location front end-stop	F	Ø 145 f7
Length [mm]	H	92
Centering length [mm]	G	15
Bolt hole circle end-stop	B	LK Ø 107 [3 x M6]
Total length [mm]	I	120
Reserve stroke axial [mm]	Q	2
Release stroke axial [mm]	R	2,5
Clamping head serrated	AM	TOP 52
Clamping head smooth	AO	TOP 52 G
Bolt hole circle	V	LK Ø 156 [6 x M8]
Outer Ø [mm]	AW	174
Weight [kg]		7
In stock		✓
Order no.	10575/0003	10575/0004

Clamping heads	Changing fixtures	End-stop systems	Adaptations I.D. clamping	Adaptations jaw clamping	Face driver	Flanges
Page 360	Page 419	Page 400	Page 268	Page 314	Page 320	Page 147



STANDARD CHUCKS Manual chuck TOROK

TOROK CFK RD. Technical data

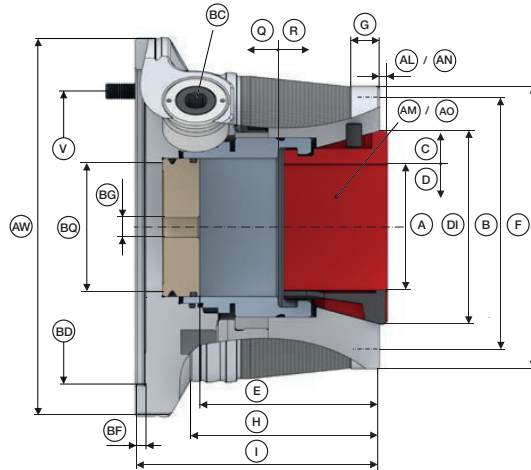

Product line	RD	
Size	52	65
Concentricity [mm]		0,010
Max. radial clamping force [kN]	94	105
Max. axial drawtube force [kN]	40	45
Flange location	BD	Ø 145 H7
Flange fit length [mm]	BF	5,1
Max. actuating torque [Nm]	BC	57
RPM n max. [1/min.]		7000
Clamping range [mm]	A	4 – 52
Release stroke in Ø [mm]	C	0,6
Reserve stroke in Ø [mm]	D	1
Range / recommended workpiece tolerance [mm]		± 0,5
End-stop depth [mm]	E	90
Ø Capacity [mm]	BQ	53
End-stop thread size [M]	BG	10
Location front end-stop	F	Ø 125 f7
Length [mm]	H	92
Centering length [mm]	G	15
Bolt hole circle end-stop	B	LK Ø 107 [3 x M6]
Total length [mm]	I	120
Reserve stroke axial [mm]	Q	2
Release stroke axial [mm]	R	2,5
Clamping head serrated	AM	SK 52 BZI
Clamping head protrusion length serrated [mm]	AL	4
Clamping head smooth	AO	SK 52 BZIG
Clamping head protrusion length smooth [mm]	AN	4
Head Ø [mm]	DI	80
Bolt hole circle	V	LK Ø 156 [6 x M8]
Outer Ø [mm]	AW	174
Weight [kg]		7,3
In stock		✓
Order no.	10576/0003	10576/0004

Clamping heads Page 368	Changing fixtures Page 419	End-stop systems Page 400	Adaptations I.D. clamping Page 268	Adaptations jaw clamping Page 314	Face driver Page 320	Flanges Page 147