

STANDARD SEGMENTED MANDRELS

Mandrel MANDO

MANDO T211 size 0 with flange. Technical data

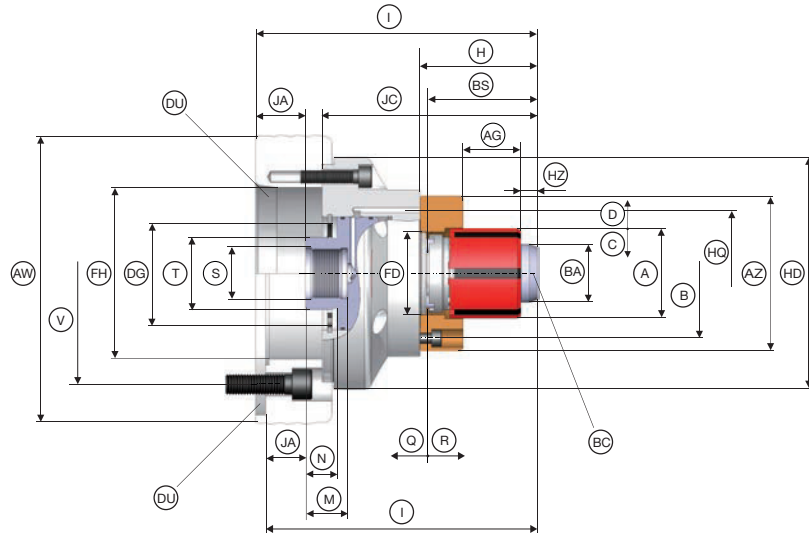

Size	0								
Clamping range [mm]	A	20 – 28							
Spindle nose	DU	A2-4	A2-5	A2-6	A2-8	AP120	AP140	AP170	AP220
Concentricity [mm]		0,010							
Max. radial clamping force [kN]		42							
Max. axial drawtube force [kN]		10							
Max. clamping length [mm]	AG	22,00							
Reserve stroke in Ø [mm]	D	0,25							
Release stroke in Ø [mm]	C	0,25							
RPM n max. [1/min.]		7000							
Reserve stroke axial [mm]	Q	1,5							
Release stroke axial [mm]	R	2							
Max. actuating torque [Nm]	BC	10							
Draw bolt Ø [mm]	BA	19							
Draw bolt head height [mm]	HZ	7,5							
Reception workpiece end-stop	FD	Ø 32 f7							
End-stop outer Ø [mm]	AZ	65							
Bolt hole circle end-stop	B	LK Ø 50 [3 x M6]							
Length [mm]	H	40							
Length 2 [mm]	BS	32,5							
Length 3 [mm]	JC	100							
Total length [mm]	I	140		144		140			
Connecting thread inside	S	M30 x 1,5							
Connecting thread outside	T	M44 x 1,5							
Distance [mm]	JA	30		34		30			
Depth of thread [mm]	M	25,5							
Thread length [mm]	N	19							
Max. drawtube Ø [mm]	DG	54							
Minimum length of DG [mm]		13							
Bore-Ø	FH	61	79,6	103,2	100	77	80	103	
Bolt hole circle	V	LK Ø 82,6 [3 x M10]	LK Ø 104,8 [6 x M10]	LK Ø 133,4 [6 x M12]	LK Ø 171,4 [6 x M16]	LK Ø 104,8 [6 x M10]		LK Ø 133,4 [6 x M12]	LK Ø 171,4 [6 x M16]
Outer Ø [mm]	AW	140		165	210	140	150	180	230
Outer Ø 2 [mm]	HD	139							
Air sensing control bolt hole circle-Ø [mm]	HQ	64							
Air sensing control bore Ø [mm]		3							
Central air sensing connection Ø optional [mm]		12 H7							
Weight [kg]		8,5	7,9	8,9	13,7	8,1	8,7	10,5	16

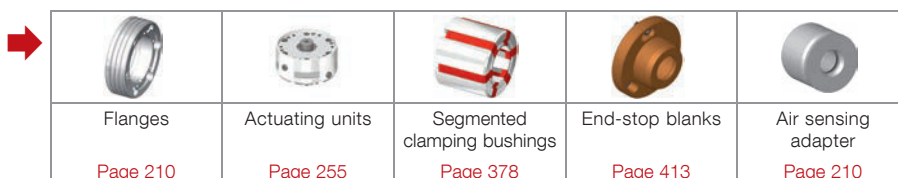

Scope of delivery

- Mandrel without spindle flange/
without air sensing adapter
- Draw bolt

STANDARD SEGMENTED MANDRELS

Mandrel MANDO

MANDO T211 size 1 with flange. Technical data

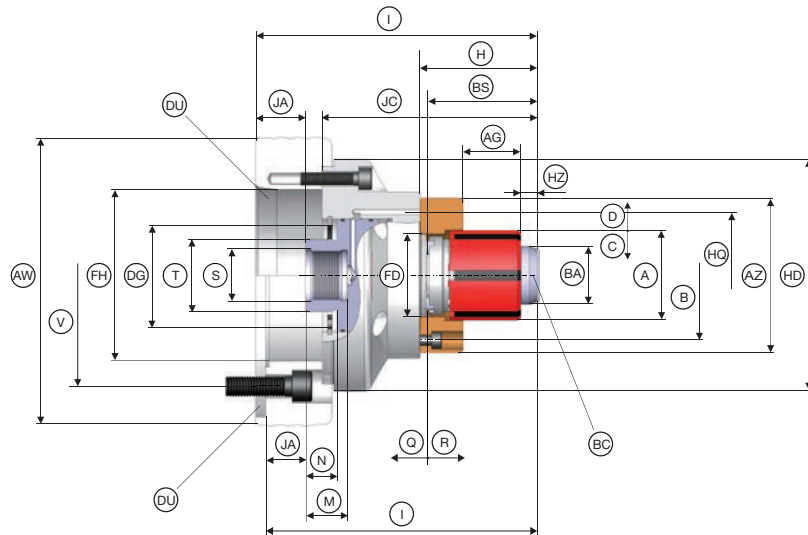

Size	1								
Clamping range [mm]	A	26 – 38							
Spindle nose	DU	A2-4	A2-5	A2-6	A2-8	AP120	AP140	AP170	AP220
Concentricity [mm]									0,010
Max. radial clamping force [kN]									42
Max. axial drawtube force [kN]									10
Max. clamping length [mm]	AG								26,00
Reserve stroke in Ø [mm]	D								0,25
Release stroke in Ø [mm]	C								0,25
RPM n max. [1/min.]									7000
Reserve stroke axial [mm]	Q								1,5
Release stroke axial [mm]	R								2
Max. actuating torque [Nm]	BC								20
Draw bolt Ø [mm]	BA								25
Draw bolt head height [mm]	HZ								11
Reception workpiece end-stop	FD								Ø 41 f7
End-stop outer Ø [mm]	AZ								69
Bolt hole circle end-stop	B								LK Ø 55 [3 x M6]
Length [mm]	H								51
Length 2 [mm]	BS								47,5
Length 3 [mm]	JC								110
Total length [mm]	I		150		154			150	
Connecting thread inside	S					M30 x 1,5			
Connecting thread outside	T					M44 x 1,5			
Distance [mm]	JA		30		34			30	
Depth of thread [mm]	M					25,5			
Thread length [mm]	N					19			
Max. drawtube Ø [mm]	DG					54			
Minimum length of DG [mm]						13			
Bore-Ø	FH	61	79,6	103,2	100	77	80		103
Bolt hole circle	V	LK Ø 82,6 [3 x M10]	LK Ø 104,8 [6 x M10]	LK Ø 133,4 [6 x M12]	LK Ø 171,4 [6 x M16]		LK Ø 104,8 [6 x M10]	LK Ø 133,4 [6 x M12]	LK Ø 171,4 [6 x M16]
Outer Ø [mm]	AW		140	165	210	140	150	180	230
Outer Ø 2 [mm]	HD					139			
Air sensing control bolt hole circle-Ø [mm]	HQ					64			
Air sensing control bore Ø [mm]						3			
Central air sensing connection Ø optional [mm]						12 H7			
Weight [kg]		8,6	8	9	13,8	8,2	8,8	10,6	16,1



Scope of delivery

- Mandrel without spindle flange/
without air sensing adapter
- Draw bolt

STANDARD SEGMENTED MANDRELS

Mandrel MANDO

MANDO T211 size 2 with flange. Technical data

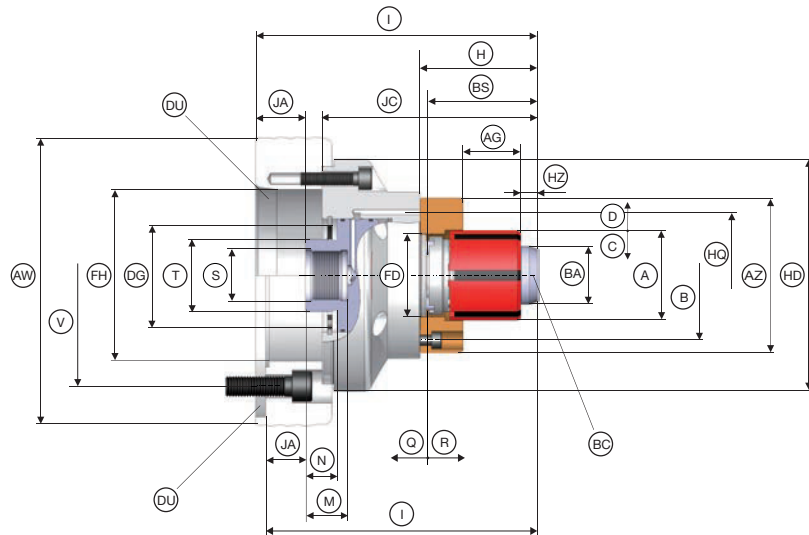

Size	2								
Clamping range [mm]	A	36 – 54							
Spindle nose	DU	A2-4	A2-5	A2-6	A2-8	AP120	AP140	AP170	AP220
Concentricity [mm]		0,010							
Max. radial clamping force [kN]		85							
Max. axial drawtube force [kN]		20							
Max. clamping length [mm]	AG	43,00							
Reserve stroke in Ø [mm]	D	0,25							
Release stroke in Ø [mm]	C	0,25							
RPM n max. [1/min.]		7000							
Reserve stroke axial [mm]	Q	1,5							
Release stroke axial [mm]	R	2,5							
Max. actuating torque [Nm]	BC	25							
Draw bolt Ø [mm]	BA	35							
Draw bolt head height [mm]	HZ	10							
Reception workpiece end-stop	FD	Ø 50 f7							
End-stop outer Ø [mm]	AZ	93							
Bolt hole circle end-stop	B	LK Ø 78 [3 x M6]							
Length [mm]	H	71							
Length 2 [mm]	BS	61							
Length 3 [mm]	JC	130							
Total length [mm]	I	170		174		170			
Connecting thread inside	S	M30 x 1,5							
Connecting thread outside	T	M44 x 1,5							
Distance [mm]	JA	30		34		30			
Depth of thread [mm]	M	25,5							
Thread length [mm]	N	19							
Max. drawtube Ø [mm]	DG	54							
Minimum length of DG [mm]		13							
Bore-Ø	FH	61	79,6	103,2	100	77	80	103	
Bolt hole circle	V	LK Ø 82,6 [3 x M10]	LK Ø 104,8 [6 x M10]	LK Ø 133,4 [6 x M12]	LK Ø 171,4 [6 x M16]	LK Ø 104,8 [6 x M10]		LK Ø 133,4 [6 x M12]	LK Ø 171,4 [6 x M16]
Outer Ø [mm]	AW	140		165	210	140	150	180	230
Outer Ø 2 [mm]	HD	139							
Air sensing control bolt hole circle-Ø [mm]	HQ	76							
Air sensing control bore Ø [mm]		3							
Central air sensing connection Ø optional [mm]		12 H7							
Weight [kg]		9,3	8,7	9,7	14,5	8,9	9,5	11,3	16,8



Scope of delivery

- Mandrel without spindle flange/
without air sensing adapter
- Draw bolt

STANDARD SEGMENTED MANDRELS

Mandrel MANDO

MANDO T211 size 3 with flange. Technical data

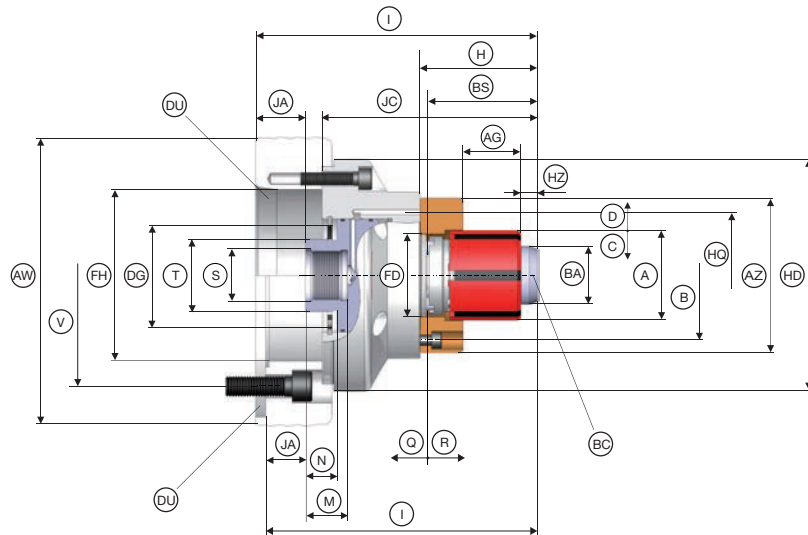

Size	3								
Clamping range [mm]	A	50 – 80							
Spindle nose	DU	A2-4	A2-5	A2-6	A2-8	AP120	AP140	AP170	AP220
Concentricity [mm]		0,010							
Max. radial clamping force [kN]		105							
Max. axial drawtube force [kN]		25							
Max. clamping length [mm]	AG	49,00							
Reserve stroke in Ø [mm]	D	0,35							
Release stroke in Ø [mm]	C	0,35							
RPM n max. [1/min.]		6000							
Reserve stroke axial [mm]	Q	2							
Release stroke axial [mm]	R	2,5							
Max. actuating torque [Nm]	BC	55							
Draw bolt Ø [mm]	BA	49							
Draw bolt head height [mm]	HZ	11							
Reception workpiece end-stop	FD	Ø 65 f7							
End-stop outer Ø [mm]	AZ	96							
Bolt hole circle end-stop	B	LK Ø 80 [3 x M6]							
Length [mm]	H	78							
Length 2 [mm]	BS	68							
Length 3 [mm]	JC	140							
Total length [mm]	I	180		184		180			
Connecting thread inside	S	M30 x 1,5							
Connecting thread outside	T	M44 x 1,5							
Distance [mm]	JA	30		34		30			
Depth of thread [mm]	M	25,5							
Thread length [mm]	N	19							
Max. drawtube Ø [mm]	DG	54							
Minimum length of DG [mm]		13							
Bore-Ø	FH	61	79,6	103,2	100	77	80	103	
Bolt hole circle	V	LK Ø 82,6 [3 x M10]	LK Ø 104,8 [6 x M10]	LK Ø 133,4 [6 x M12]	LK Ø 171,4 [6 x M16]	LK Ø 104,8 [6 x M10]		LK Ø 133,4 [6 x M12]	LK Ø 171,4 [6 x M16]
Outer Ø [mm]	AW	140		165	210	140	150	180	230
Outer Ø 2 [mm]	HD	139							
Air sensing control bolt hole circle-Ø [mm]	HQ	78							
Air sensing control bore Ø [mm]		3							
Central air sensing connection Ø optional [mm]		12 H7							
Weight [kg]		10,1	9,5	10,5	15,3	9,7	10,3	12,1	17,6



Scope of delivery

- Mandrel without spindle flange/
without air sensing adapter
- Draw bolt

STANDARD SEGMENTED MANDRELS

Mandrel MANDO

MANDO T211 size 4 with flange. Technical data

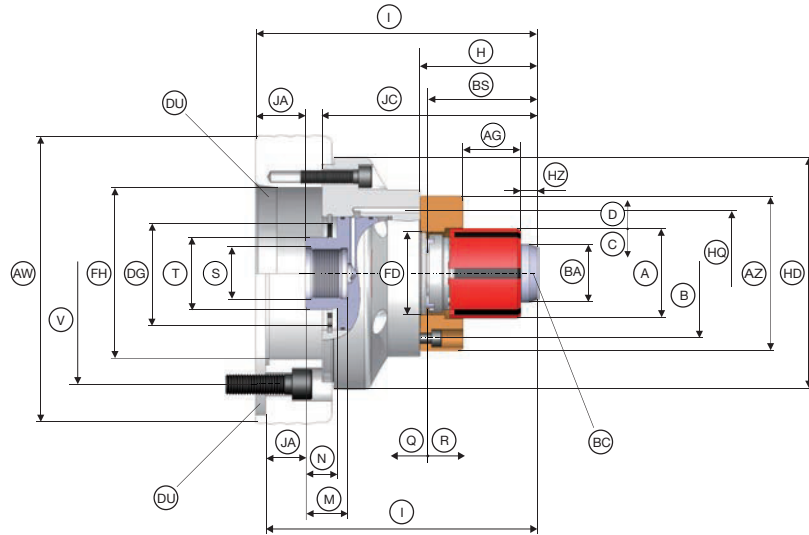

Size	4								
Clamping range [mm]	A	69 - 120							
Spindle nose	DU	A2-4	A2-5	A2-6	A2-8	AP120	AP140	AP170	AP220
Concentricity [mm]									0,010
Max. radial clamping force [kN]									150
Max. axial drawtube force [kN]									35
Max. clamping length [mm]	AG								59,00
Reserve stroke in Ø [mm]	D								0,4
Release stroke in Ø [mm]	C								0,4
RPM n max. [1/min.]									6000
Reserve stroke axial [mm]	Q								2,5
Release stroke axial [mm]	R								3
Max. actuating torque [Nm]	BC								55
Draw bolt Ø [mm]	BA								68
Draw bolt head height [mm]	HZ								16
Reception workpiece end-stop	FD								Ø 78 f7
End-stop outer Ø [mm]	AZ								100
Bolt hole circle end-stop	B								LK Ø 90 [3 x M6]
Length [mm]	H								98
Length 2 [mm]	BS								80
Length 3 [mm]	JC								155
Total length [mm]	I		195		199			195	
Connecting thread inside	S								M30 x 1,5
Connecting thread outside	T								M44 x 1,5
Distance [mm]	JA		30		34			30	
Depth of thread [mm]	M								27
Thread length [mm]	N								19
Max. drawtube Ø [mm]	DG								60
Minimum length of DG [mm]									13
Bore-Ø	FH	61	79,6	103,2	100	77	80		103
Bolt hole circle	V	LK Ø 82,6 [3 x M10]	LK Ø 104,8 [6 x M10]	LK Ø 133,4 [6 x M12]	LK Ø 171,4 [6 x M16]		LK Ø 104,8 [6 x M10]	LK Ø 133,4 [6 x M12]	LK Ø 171,4 [6 x M16]
Outer Ø [mm]	AW	140		165	210	140	150	180	230
Outer Ø 2 [mm]	HD	139							
Air sensing control bolt hole circle-Ø [mm]	HQ	91							
Air sensing control bore Ø [mm]		3							
Central air sensing connection Ø optional [mm]		12 H7							
Weight [kg]		11,3	10,7	11,7	16,5	10,9	11,5	13,3	18,8

For size 4, clamping range 101 - 120 mm, a max. speed of 4200 RPM applies.

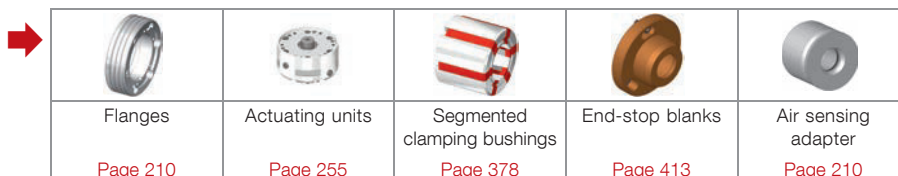

Scope of delivery

- Mandrel without spindle flange/
without air sensing adapter
- Draw bolt

STANDARD SEGMENTED MANDRELS

Mandrel MANDO

MANDO T211 size 5 with flange. Technical data

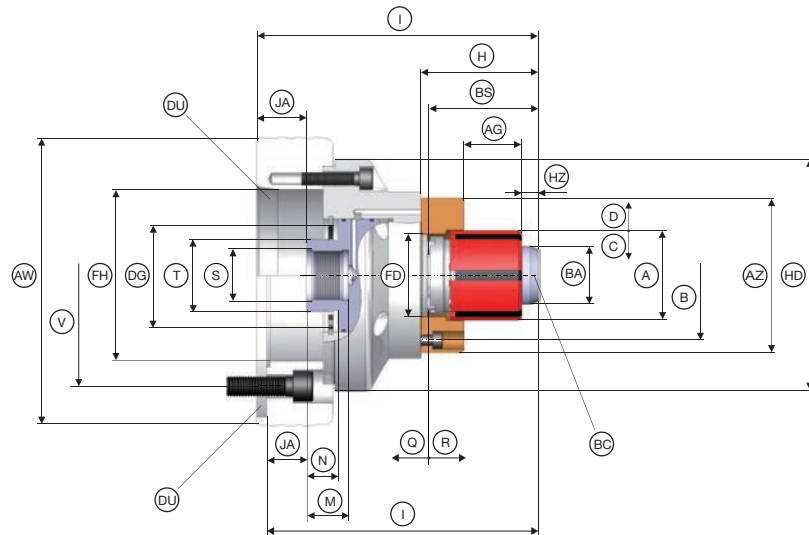

Size	5			
Clamping range [mm]	A	100 – 130		
Spindle nose	DU	A2-6	A2-8	A2-11
Concentricity [mm]			0,010	
Max. radial clamping force [kN]			170	
Max. axial drawtube force [kN]			40	
Max. clamping length [mm]	AG		86	
Reserve stroke in Ø [mm]	D		0,5	
Release stroke in Ø [mm]	C		0,5	
RPM n max. [1/min.]			5000	
Reserve stroke axial [mm]	Q		3	
Release stroke axial [mm]	R		3	
Max. actuating torque [Nm]	BC		65	
Draw bolt Ø [mm]	BA		97	
Draw bolt head height [mm]	HZ		16	
Reception workpiece end-stop	FD		Ø 102 f7	
End-stop outer Ø [mm]	AZ		150	
Bolt hole circle end-stop	B		LK Ø 117 [3 x M6]	
Length [mm]	H		120	
Length 2 [mm]	BS		112,5	
Length 3 [mm]	JC		195	
Total length [mm]	I	258,5	262,5	268,5
Connecting thread inside	S		M30 x 1,5	
Connecting thread outside	T		M44 x 1,5	
Distance [mm]	JA	53,5		63,5
Depth of thread [mm]	M		25,5	
Thread length [mm]	N		19	
Max. drawtube Ø [mm]	DG		97	
Minimum length of DG [mm]			12	
Bore-Ø	FH	103,2	136,2	155
Bolt hole circle	V	LK Ø 133,4 [6 x M12]	LK Ø 171,4 [6 x M16]	LK Ø 235 [6 x M20]
Outer Ø [mm]	AW		235	280
Outer Ø 2 [mm]	HD		230	
Weight [kg]		36	35	45



Scope of delivery

- Mandrel without spindle flange/
without air sensing adapter
- Draw bolt



STANDARD SEGMENTED MANDRELS

Mandrel MANDO

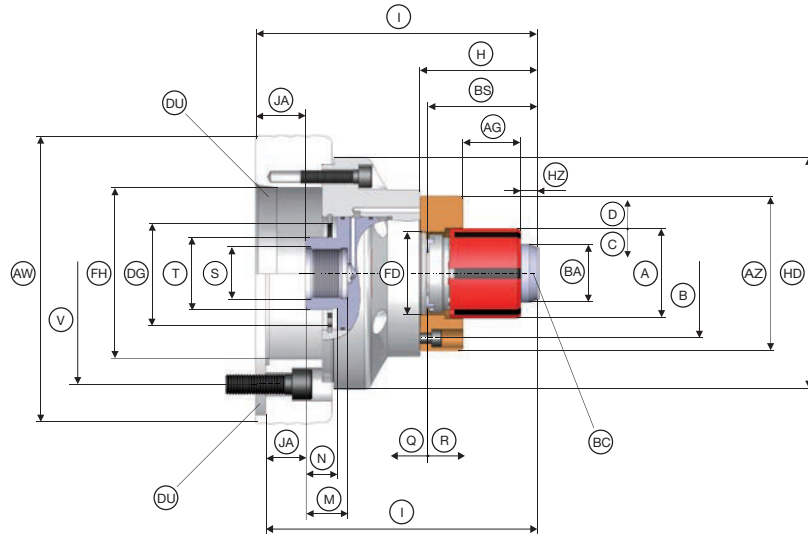
MANDO T211 size 6 with flange. Technical data



Size	6		
Clamping range [mm]	A	130 – 160	
Spindle nose	DU	A2-6	A2-8
Concentricity [mm]			0,010
Max. radial clamping force [kN]			170
Max. axial drawtube force [kN]			40
Max. clamping length [mm]	AG		96
Reserve stroke in Ø [mm]	D		0,5
Release stroke in Ø [mm]	C		0,5
RPM n max. [1/min.]			4000
Reserve stroke axial [mm]	Q		3
Release stroke axial [mm]	R		3
Max. actuating torque [Nm]	BC		65
Draw bolt Ø [mm]	BA		125
Draw bolt head height [mm]	HZ		25
Reception workpiece end-stop	FD		Ø 132 f7
End-stop outer Ø [mm]	AZ		180
Bolt hole circle end-stop	B		LK Ø 148 [3 x M6]
Length [mm]	H		137
Length 2 [mm]	BS		129,5
Length 3 [mm]	JC		220
Total length [mm]	I	283,5	287,5
Connecting thread inside	S		M30 x 1,5
Connecting thread outside	T		M44 x 1,5
Distance [mm]	JA	53,5	63,5
Depth of thread [mm]	M		25,5
Thread length [mm]	N		19
Max. drawtube Ø [mm]	DG		120
Minimum length of DG [mm]			12
Bore-Ø	FH	103,2	136,2
Bolt hole circle	V	LK Ø 133,4 [6 x M12]	LK Ø 171,4 [6 x M16]
Outer Ø [mm]	AW	235	LK Ø 235 [6 x M20]
Outer Ø 2 [mm]	HD		280
Weight [kg]		43	53

				
Flanges	Actuating units	Segmented clamping bushings	End-stop blanks	Air sensing adapter
Page 210	Page 255	Page 378	Page 413	Page 210

Scope of delivery

- Mandrel without spindle flange/
without air sensing adapter
- Draw bolt

STANDARD SEGMENTED MANDRELS

Mandrel MANDO

MANDO T211 size 7 with flange. Technical data

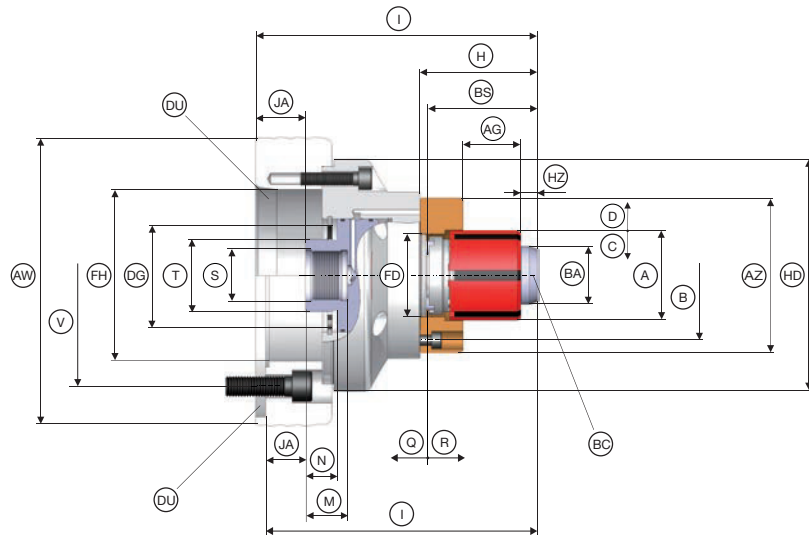

Size	7			
Clamping range [mm]	A	160 – 200		
Spindle nose	DU	A2-6	A2-8	A2-11
Concentricity [mm]			0,010	
Max. radial clamping force [kN]			170	
Max. axial drawtube force [kN]			45	
Max. clamping length [mm]	AG		94	
Reserve stroke in Ø [mm]	D		0,5	
Release stroke in Ø [mm]	C		0,5	
RPM n max. [1/min.]			3200	
Reserve stroke axial [mm]	Q		3	
Release stroke axial [mm]	R		3	
Max. actuating torque [Nm]	BC		65	
Draw bolt Ø [mm]	BA		156	
Draw bolt head height [mm]	HZ		29,5	
Reception workpiece end-stop	FD		Ø 162 f7	
End-stop outer Ø [mm]	AZ		220	
Bolt hole circle end-stop	B		LK Ø 177 [3 x M8]	
Length [mm]	H		155	
Length 2 [mm]	BS		184	
Length 3 [mm]	JC		245	
Total length [mm]	I	308,5	312,5	318,5
Connecting thread inside	S		M30 x 1,5	
Connecting thread outside	T		M44 x 1,5	
Distance [mm]	JA	53,5		63,5
Depth of thread [mm]	M		25,5	
Thread length [mm]	N		19	
Max. drawtube Ø [mm]	DG		140	
Minimum length of DG [mm]			12	
Bore-Ø	FH	103,2	136,2	155
Bolt hole circle	V	LK Ø 133,4 [6 x M12]	LK Ø 171,4 [6 x M16]	LK Ø 235 [6 x M20]
Outer Ø [mm]	AW		235	280
Outer Ø 2 [mm]	HD		230	
Weight [kg]		55	54	64

				
Flanges	Actuating units	Segmented clamping bushings	End-stop blanks	Air sensing adapter
Page 210	Page 255	Page 378	Page 413	Page 210

Scope of delivery

- Mandrel without spindle flange/
without air sensing adapter
- Draw bolt