

Installation manual

EN

Segmented mandrel
MANDO T211 RD

Table of contents

1	General.....	5
1.1	Information about this manual.....	5
1.2	Explanation of symbols.....	5
1.3	Limitations of liability.....	6
1.4	Max. RPM.....	6
1.5	Copyright.....	7
1.6	Scope of delivery.....	7
1.7	Spare parts.....	7
1.8	Warranty terms.....	7
2	Safety.....	8
2.1	Responsibility of the customer.....	8
2.2	Personnel requirements.....	9
2.3	Intended use.....	10
2.4	Personal protective equipment.....	11
2.5	Special dangers.....	12
2.6	Further warnings.....	15
2.7	Clamping force.....	16
2.8	Functionality.....	17
2.9	Environmental protection.....	17
3	Technical data.....	18
3.1	General information.....	18
3.2	Operating conditions.....	19
3.3	Power specifications.....	19
3.4	Check.....	19
3.5	Type designation.....	19
4	Structure and function.....	20
4.1	Overview and brief description.....	20
4.2	Optional Accessories.....	21
4.2.1	Spindle flange.....	21
4.2.2	mandoteX adapter.....	22
4.2.3	Segmented clamping bushing.....	22
4.2.4	Workpiece end-stop.....	22
4.2.5	Grease.....	23
4.2.6	Grease gun.....	23
5	Transporting, packaging and storing.....	24
5.1	Safety instructions for transporting.....	24
5.2	Symbols on the packaging.....	24
5.3	Transport inspection.....	25
5.4	Unpacking and inner-company transport.....	25
5.5	Packaging.....	26
5.6	Storing.....	27

6	Assembly.....	28
6.1	Pre-consideration.....	28
6.2	Preparations.....	29
6.3	Assembly.....	30
6.3.1	Assembling the flange [optional].....	33
6.3.2	Adjusting the concentricity of the spindle flange.....	34
6.3.3	Checking face run and concentricity.....	35
6.3.4	Assembling the quick-change machine adapter.....	35
6.3.5	Assembly of the segmented mandrel [machine spindle].....	36
6.3.6	Assembly of the segmented mandrel [bayonet].....	37
6.3.7	Assembly of the segmented mandrel [clamping mechanism].....	38
6.3.8	Assembly of the segmented mandrel [ms dock / hs dock].....	39
6.3.9	Assembly of the segmented mandrel [quick change-over interface].	39
6.3.10	Assembly of the segmented mandrel [mandoteX].....	40
6.3.11	Face run and concentricity.....	40
6.3.12	Assembling of the workpiece end-stop.....	41
6.3.13	Assembly of the segmented clamping bushing RD.....	43
6.4	Workpiece.....	45
6.5	Tests.....	46
6.6	Control of the stroke position.....	47
6.7	Activities after production is concluded.....	47
7	Disassembly.....	48
7.1	Safety.....	48
7.2	Disassembling the clamping device.....	49
7.2.1	Disassembly of the segmented clamping bushing.....	49
7.2.2	Disassembling the workpiece end-stop.....	50
7.2.3	Disassembly of the segmented mandrel [machine spindle].....	50
7.2.4	Disassembly of the segmented mandrel [bayonet].....	51
7.2.5	Disassembling the segmented mandrel [clamping mechanism].....	51
7.2.6	Disassembling the segmented mandrel [ms dock / hs dock].....	52
7.2.7	Disassembling the segmented mandrel [quick change interface].	52
7.2.8	Disassembly of the segmented mandrel [mandoteX].....	52
7.2.9	Disassembling the spindle flange.....	53
7.2.10	Disassembly of the quick-change machine adapter [optional].	53
7.3	Subsequent storage of the clamping device.....	54
7.4	Disposal.....	54
8	Maintenance.....	55
8.1	General.....	55
8.2	Cleaning.....	56
8.3	Preservation.....	57
8.4	Use of lubricant.....	57
8.5	Maintenance schedule.....	58
8.6	Bolt torque.....	59

9	Trouble shooting.....	60
9.1	Safety.....	60
9.2	Trouble shooting table.....	61
9.3	Start-up after corrected fault.....	62
10	Appendix.....	63
10.1	Service Hotline.....	63
10.2	Representatives.....	63
10.2.1	Europe.....	63
10.2.2	North america.....	66
10.2.3	South america.....	66
10.2.4	Asia.....	66
10.2.5	Australia.....	67
10.2.6	Africa.....	67
	Index.....	68
	EC Declaration of conformity.....	71

1 General

1.1 Information about this manual

This manual enables safe and efficient handling of the clamping device.

The manual is a component of the clamping device and must be kept in the immediate vicinity of the clamping device where it is accessible for personnel at all times. Personnel must have carefully read and understood this manual prior to starting all tasks. The basic prerequisite for safe work is compliance with all the safety instructions and handling instructions in this manual.

Illustrations in this manual are provided for a basic understanding and may deviate from the actual model of the clamping device.

It is assumed that the reader is familiar with standard procedures, such as cleaning the mounting surfaces.

1.2 Explanation of symbols

Safety instructions

Safety instructions are indicated by symbols in this operating manual. The safety instructions are introduced by signal words that express the scope of the hazard.

The safety instructions must be strictly adhered to. You must act prudently to prevent accidents, personal injury, and material damage.



DANGER

... indicates an imminent dangerous situation that can result in death or serious injury if it is not avoided.



WARNING

... indicates a possible dangerous situation that can result in death or serious injury if it is not avoided.



CAUTION

... indicates a possible dangerous situation that can result in minor or light injury if it is not avoided.



NOTE

... indicates a possible dangerous situation that can result in material damage if it is not avoided.

Tips and recommendations



... indicates useful tips and recommendations, as well as information for efficient and trouble-free operation.

1.3 Limitations of liability

All information and instructions in this operating manual have been provided under due consideration of applicable standards and regulations, the current state of technology, as well as our many years of experience.

The manufacturer assumes no liability for damage due to:

- Failure to follow the instructions in the manual
- Non-intended use
- Deployment of untrained personnel
- Unauthorized conversions
- Technical changes
- Use of non-approved spare parts

The actual scope of delivery can vary from the explanations and graphic representations provided in this manual in the case of special versions, if supplemental order options are desired, or on the basis of the latest technical changes.

The agreed obligations in the delivery contract, the general terms and conditions, as well as delivery conditions of the manufacturer, and the statutory regulations valid at the time the contract was concluded, apply.

1.4 Max. RPM



CAUTION!

The maximum permissible speed is marked on the product.

Note that the clamping force is influenced by the centrifugal force of the clamping elements.

- If necessary, adjust the machining force!

1.5 Copyright

This manual is protected by copyright and is provided exclusively for internal purposes.

Delivery of the operating manual to third parties, duplication in any form – including excerpts – as well as exploitation and/or communication of the content, are not permitted [except for internal use] without written approval from the manufacturer.

Actions to the contrary make damage compensation mandatory. We reserve the right to enforce additional claims.

1.6 Scope of delivery



All tools and accessories that are not included in the scope of delivery are marked as optional.

In scope of delivery of the clamping device:

- 1 segmented mandrel

Optionally the scope of delivery of the clamping device includes:

- Spindle flange
- Segmented clamping bushing
- Workpiece end-stop
- Drawtube adapter
- Eye bolts

1.7 Spare parts



WARNING!

Safety risk if the wrong spare parts are used!

Incorrect or defective spare parts can cause damage, malfunction, or total failure; they can also impair safety.

- Only use manufacturer's original spare parts.

Only purchase spare parts from authorized dealers or direct from the manufacturer. Addresses are in the appendix.

1.8 Warranty terms

The warranty terms are included in the manufacturer's terms and conditions.

2 Safety

This section provides an overview of all the important safety aspects for optimal protection of personnel, as well as for safe and trouble-free operation.

2.1 Responsibility of the customer

The product is used in industrial applications. Consequently the owner of the product is subject to legal industrial safety obligations.

In addition to the safety instruction in this manual, generally valid safety and accident protection guidelines, and environmental protection guidelines as well as the machines' manual must be adhered to and complied with for the area of implementation of the device.

Note in particular that the status scans of the machine must be adjusted to the respective product.



DANGER!

Risk of injury due to thrown out parts!

Incorrect machine settings may lead to the throwing out of parts.

- The status scans the machine must be set to the respective clamping device.
- Regularly check the status scans of the machine, see chapter »Maintenance Schedule«. If the end position can not be reached the product may no longer be used.
- Observe the operating instructions of the machine.



WARNING!

Risk of injury!

Declining operating force, for example by declining energy supply, may cause serious personal injury.

- The product may be used only on machines where it is ensured, that during use, the operating force does not drop.



WARNING!

Risk of injury!

An incorrect media supply [hydraulic, pneumatic], e.g. by damaged or missing seals or pipes, can cause serious personal injury.

- Hydraulic and / or pneumatic tubes must be secured by the machine by check valves and a permanent pressure monitoring!

2.2 Personnel requirements



WARNING!

Danger of injury due to insufficient qualification!

Improper handling of the clamping device can cause serious injury or material damage.

- Only have activities performed by personnel who are qualified to perform these activities.

The following qualifications are cited in the operating manual for the various activity areas.

■ **Specialized personnel**

are personnel who due to their specialized training, skills, and experience, as well as knowledge of the applicable regulations, are capable of executing the tasks assigned to them and of recognizing and avoiding possible hazards on their own.

■ **Hydraulic specialist**

The hydraulic specialist has been trained for the particular task area in which he is active and is familiar with the relevant standards and regulations. Due to his specialized training and experience the hydraulic specialist can perform tasks on hydraulic equipment and recognize and avoid possible dangers on his own.

■ **Electric specialist**

The electric specialist has been trained for the particular task area in which he is active and is familiar with the relevant standards and regulations. Due to his specialized training and experience the electric specialist can perform tasks on electric equipment and recognize and avoid possible dangers on his own.

Only persons from whom it can be expected that they

reliably execute their work are considered as personnel. Persons whose capability to react is impaired, for instance through drugs, alcohol, or medication, are not approved.

- Comply with age-specific and job-specific regulations that are applicable at the installation site when selecting personnel.

2.3 Intended use

The clamping device is designed for installation in a machine tool according to CE compliant.

The clamping device should only be mounted, operated, maintained, and cleaned by instructed, specialized personnel.

Intended use also includes compliance with all the instructions in this manual.

The clamping device is to be used for the case of application contractually agreed between the producer/deliverer and the user, as well as such cases of application described in the product description which are also in accordance with the technical values.

The safe function of the clamping device is, as far as it can be foreseen, guaranteed when it is used for the intended purpose in accordance with the appropriate safety regulations.

Any use that extends beyond the intended use, or any other use of the clamping device is considered to be misuse and can cause dangerous situations.

Segmented mandrels are designed and developed for location of workpieces for machining of rotationally-symmetric workpieces. Other fields of application require an explicit approval by the manufacturer.



WARNING!

Risk of injury!

Never start rotating the clamping device without a clamped workpiece.

- For operation any available clamping position must be clamped with a suitable workpiece.



WARNING!

Danger due to misuse!

Misuse of the clamping device can cause dangerous situations.

Particularly refrain from the following uses of the clamping device:

- Use in machines other than machine tools.
- Use in machine tools with technical data other than that specified on the clamping device.

Claims of any type due to damage arising from non-intended use are excluded.

Unintended and improper use of the Power Chuck is for example

- If workpieces are not clamped properly
- If safety regulations are disregarded and persons are working at the clamping device without additional protective devices e.g. for machining.
- If the clamping device is used for machines or tools for which it is not intended.

2.4 Personal protective equipment

Wearing of personal protective equipment is required to minimize health hazards when working with the device.

- Always wear the protective equipment necessary for the respective task when working with the device.
- Follow the instructions that have been posted in the work area.

Always wear



For all tasks always wear:

Protective work clothing

is tight-fitting work clothing with low resistance to tearing, with tight sleeves, and without projecting parts. It is primarily used to protect against entanglement by moving machine parts.

Do not wear rings, chains, or other jewelry.



Safety footwear

for protection against heavy falling parts and slipping on slippery substrates.

For special tasks wear



Special protective equipment is required when executing special tasks. Separate reference is made to this equipment in the specific sections of this manual. This special protective equipment is explained below:

Hard hat

to protect against falling and flying parts and materials.

Protective goggles

to protect eyes from flying parts and liquid splashes.

Protective gloves

to protect hands from friction, abrasion, puncture wounds, or deeper injuries, as well as from contact with hot surfaces.

2.5 Special dangers

In the following section residual risks are cited that occur due to installation of the clamping device in a machine tool. In each case the residual risks that have been determined based on a risk analysis of the machine must be specified by the customer.

- Follow the safety instructions listed here and the warnings in the other sections of this manual to reduce health hazards and to avoid dangerous situations.

Horizontal / lying parts



WARNING!

Danger of injury due to horizontal parts!

Before transporting the clamping device in horizontal condition:

- Put the clamping device on a non-slip pad
- Screw in the eye bolts

Suspended loads



WARNING!

Life-threatening danger due to suspended loads!

Clamping device with weight more than 15 kg must be lifted with a crane. When lifting the clamping device there is a life-threatening hazard due to falling parts or parts swinging out of control.

- Never step under suspended loads.
- Comply with the instructions concerning the intended attachment points. Ensure that the sling gear is securely seated!
- Do not attach lifting gear in projecting components.
- Only use approved hoists and sling gear with sufficient bearing capacity.
- Do not use rope and belts that are torn or frayed.

Moving parts



WARNING!

Danger of injury due to moving parts!

Rotating parts of the clamping device can cause serious injuries.

- Do not reach into moving parts or handle moving parts during operation.
- Pay attention to the clearance of moving parts.
- Do not open covers when the device is in operation.
- Be aware of afterrun time:
Prior to opening the covers ensure that all parts have come to a standstill.
- Wear tight-fitting protective work clothing in the danger zone.

Wrong clamping of the workpiece



WARNING!

Danger of injury due to incorrect clamping of the workpiece!

Incorrect workpiece clamping may lead to the ejection of the workpiece and result in serious injuries.

Under dimensioned parts can lead to incorrect clamping!

- Check the unmachined workpieces at random on dimensional accuracy.

Too low axial clamping force can lead to the reduction of radial clamping force!

Too high axial clamping force can lead to damage of the components of the clamping device!

- Check and adjust, if necessary, the axial clamping force regularly.

Missing changing parts



WARNING!

Danger of injury due to missing changing parts!

When operating the clamping device without changing parts [segmented clamping bushing, workpiece end-stop] there is a higher danger of crushing injuries due to the stroke of movable components of the clamping device.

- The clamping process may not be initiated without assembled segmented clamping bushing and/or workpiece end-stop.

Parts with sharp edges



WARNING!

Risk of injury!

When screwing in individual components such as for example workpiece end-stops, threaded adapters and similar devices that are equipped with an external thread or wear caused by burrs, there is risk of cutting.

- The operation must be done only by qualified personnel.
- Wearing of gloves / [PSA / personal protective equipment] is required!



CAUTION!

Risk of injury!

A special use-dependent or job-based design can result in variations in the clamping strokes and thus the clamping force.

- The notes on the associated clamping situations or product drawing must always be observed

2.6 Further warnings



WARNING!

Risk of injury!

Never start rotating the clamping device without a clamped workpiece.

- For operation any available clamping position must be clamped with a suitable workpiece.



WARNING!

Risk of injury!

Never reach for the clamping device while the spindle is rotating. Before starting to work on the mandrel, make sure the machine spindle cannot be put in motion.



WARNING!

Risk of injury!

Falling down of the clamping device or its parts can cause severe bruises and fractures.

The dead weight of the clamping device or its parts can lead to high physical stress.



WARNING!

Risk of injury!

By repeated reworking or wear and tear of the clamping surfaces sharp edges and burrs may appear and lead to severe cutting damages.



WARNING!

Risk of injury!

Missing o-rings or seals may cause severe injuries!

Due to missing / fallen out O-rings and seals compressed air or hydraulic fluids which are under high pressure may expel!

- Make sure that all O-rings / seals for the hydraulic / pneumatic connections are available and undamaged!
- If necessary lubricate them before assembly and/or during service.



WARNING!

Damage of clamping device!

The clamping device may be released exclusively in the non-rotating condition!



Risk of injury!

Leaking [sprayed out] hydraulic oil can cause serious injury.

- Make sure that all O-rings / seals for the hydraulic and/or pneumatic connections are available and undamaged



WARNING!

Risk of injury!

The operating screw may be turned out and/or thrown off!

- Never put the machine adapter into rotation if the operating system is not tightened with the given tightening torque!

2.7 Clamping force

The achieved clamping force can vary due to the maintenance condition of the clamping device [state of lubrication and degree of contamination] [see chapter »Maintenance«].

The clamping force must be checked at regular intervals. This requires the use of static clamping force measuring devices.



CAUTION!

Damages due to excessive draw and compressive force!

An excessive draw force and/or compressive force may damage the clamping device and/or the drawtube adapter.

- The max. draw force and compressive force may not be exceeded.

2.8 Functionality



NOTICE!

With high contamination of the clamping device the functionality is no longer guaranteed.

- The cleaning and maintenance intervals must be observed.

2.9 Environmental protection



NOTE!

Environmental hazard due to incorrect handling!

Incorrect handling of environmentally hazardous substances, particularly improper disposal, can cause significant environmental damage.

- Always comply with the instructions cited below
- If environmentally harmful substances should inadvertently get into the environment, initiate suitable measures immediately. If in doubt notify the responsible municipal authority about the damage.

The following environmentally harmful substances are used:

Lubricants

Lubricants like greases and oils can contain toxic substances. Ensure that they do not get into the environment.

The device must be disposed of by a specialized disposal company.

To achieve trouble-free operational performance of the clamping device only use HAINBUCH lubricants. See the appendix for reference addresses.

3 Technical data

3.1 General information

Size	Clamping range [mm]	Dimensions [ø x length in mm]	Speed max. [1/min]	Clamping force F_{rad} max. [kN]	Clamping force F_{ax} max. [kN]	Weight [kg]
0	ø20 - ø28	Ø 139 x 100	7000	42	10	5
1	ø26 - ø38	Ø 139 x 110	7000	42	10	5
2	ø36 - ø54	Ø 139 x 130	7000	85	20	5,5
3	ø50 - ø80	Ø 139 x 140	6000	105	25	6
4	ø70 - ø120	Ø 139 x 155	6000	150	35	7
5	ø100 - ø130	Ø 230 x 195	5000	170	40	23
6	ø130- ø160	Ø 230 x 220	4000	170	40	31
7	ø160 - ø200	Ø 230 x 245	3200	170	45	42

Frad max. can only be reached in lubricated condition.
In unlubricated condition Frad max. is much lower.



WARNING!

Risk of injury!

Using false technical data can lead to serious personal injury and property damage.

- The technical data [label on the product, assembly drawing] must be observed and may not be modified by the operator!

3.2 Operating conditions

Environment	Specification	Value	Unit
	Temperature range	15 - 65	°C

Mechanical actuating In each possible operating condition the maximum draw force and compressive force may not be exceeded!

3.3 Power specifications



NOTE!

Material damage if the power specifications do not agree!

If the power specifications of clamping device, machine adapter and machine do not agree, severe damage extending to total damage can occur.

- Only assemble clamping devices and adapters in machines with the same power specifications.

Information on maximum clamping force and draw-tube force is provided on the clamping device and the adapter.

- If the power values become unreadable through the abrasive effect, please refer from the manual and/or get in contact to the manufacturer.

3.4 Check

Static test

Used coefficient: **1.25**

3.5 Type designation



The type designation is on the product and includes the following information:

- 1 ID no. [marked with the # symbol]
- 2 maximum RPM [1/min]
- 3 maximum axial and radial clamping force [kN]

Fig. 1

4 Structure and function

4.1 Overview and brief description

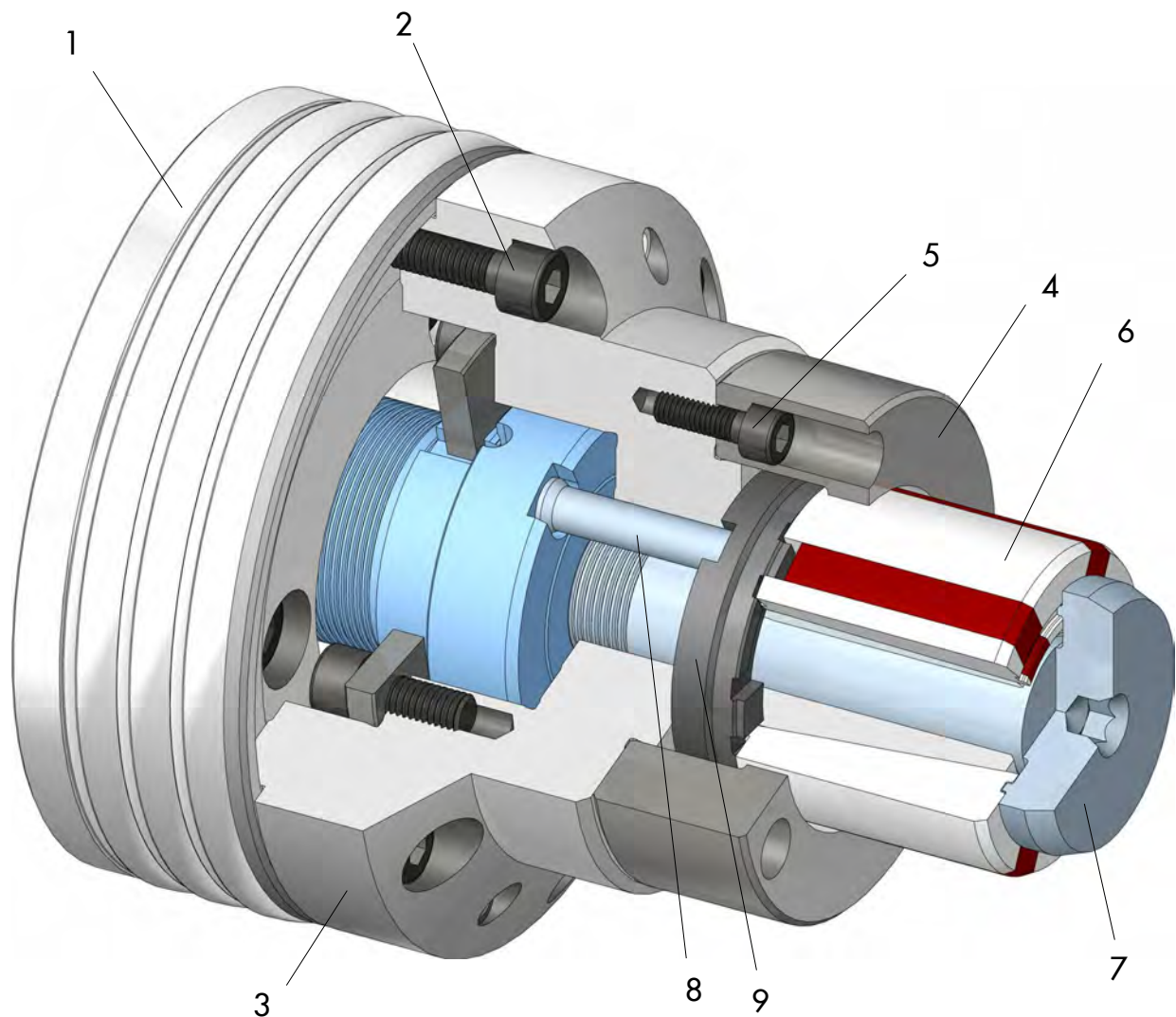

* Illustration only exemplary

Fig. 2

- | | |
|---------------------------------|-----------------------------------|
| 1. Spindle flange | 6. Segmented clamping bushing |
| 2. Cylindrical screws | 7. Draw bolt |
| 3. Mandrel body | 8. Ejector pin for forced release |
| 4. End-stop | 9. Ejector |
| 5. Mounting screws for end-stop | |

Brief description

The segmented mandrel MANDO T211 is especially suited for internal clamping.

The segmented clamping bushings consist of hardened steel segments which are vulcanized together. The functional surfaces are grinded completely during machining in one process, therefore a maximum concentricity is guaranteed.

Due to the axial effective drawtube force [pull-back effect] that is produced by the drawtube component the workpiece is pulled firmly onto the fixed end-stop. Thus extremely stable clamping of the workpiece is achieved even with the shortest clamping lengths. An additional benefit is the tremendous rigidity of the entire clamping device, which greatly increases the machining result and the tool life.

4.2 Optional Accessories

The accessories described here are not included in the scope of delivery.

Specially developed segmented clamping bushings match to the respective maximum RPM and are available for each clamping device. Trouble-free and precise function of HAINBUCH clamping devices is only ensured when using original HAINBUCH segmented clamping bushings.

Lubricating grease and grease gun are required for cleaning and preservation of the clamping device. The lubricating grease is also specially matched for protection of the vulcanized segments of the segmented clamping bushings and increase their service life and elasticity by a significant factor.

4.2.1 Spindle flange

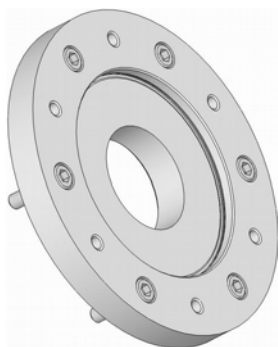

Fig. 3

The spindle flange serves for adaption of the segmented mandrel to the machine.

Depending on the order the spindle flange can be included in the delivery or provided by the customer.

4.2.2 mandoteX adapter

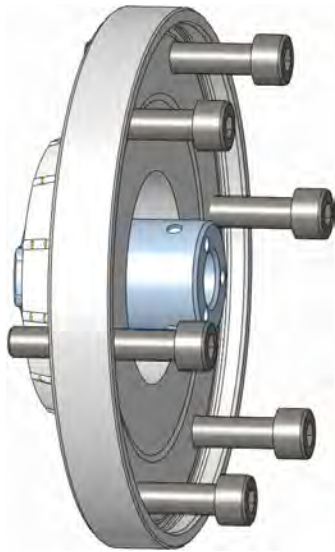

Fig. 4

By using the quick change interface mandoteX the mandrel is set-up in less than 1 minute.

- repeatability of less than 0.002 mm without adjusting
- Connection to the machine adapter by the adaptation set.

The mandoteX adapter can be ordered from HAINBUCH.

4.2.3 Segmented clamping bushing



Fig. 5

The segmented clamping bushing is offered with a clamping diameter manufactured according to the customers needs.

4.2.4 Workpiece end-stop

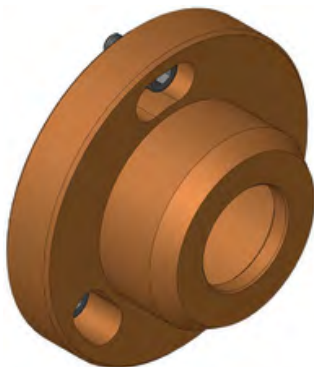

Fig. 6

The workpiece end-stop is manufactured with a end-stop dimension according to the customers request. In combination with the segmented clamping bushing and the segmented mandrel it provides a functional unit.

4.2.5 Grease



Fig. 7

The universal grease for chuck and mandrel lubrication is supplied in a 1000g can. The order number for the universal grease is 2085/0003; it can be ordered from HAINBUCH.

4.2.6 Grease gun



Fig. 8

The grease gun is filled with universal grease, which is pressed into the clamping device. The grease gun has a pointed mouthpiece. The order number for the grease gun is 2086/0004; it can be ordered from HAINBUCH.

5 Transporting, packaging and storing

5.1 Safety instructions for transporting

Unbalanced package



WARNING!

Danger of falling due to an unbalanced package

Packed goods can have an unbalanced package. If attached incorrectly the package can tip and cause life-threatening injuries.

- Note the markings on the packages.
- Attach the crane hook in such a manner that it is located above the center of gravity.
- Carefully lift and see if the load tilts. If necessary change the attachment.



Transport!

- For transport always use a suitable clamping means / crane.
- Make sure that a rolling / falling of the clamping device is not possible.

5.2 Symbols on the packaging



Fragile

Identifies packages with fragile or sensitive contents. Handle the packed goods with care; do not allow them to fall, and do not subject them to impact.



Protect from moisture

Keep packed goods dry and protected against moisture.

5.3 Transport inspection

Check delivery immediately upon receipt to ensure that delivery is complete and to identify any transport damage.

Proceed as follows if there is apparent external damage:

- Do not accept the delivery, or only accept it with reservation.
- Note the extent of transport damage on the transport documents or on the transport company's delivery ticket.
- Submit a complaint.



Report any defect as soon as it is detected. Claims for damage compensation can only be enforced during the applicable periods for giving notice of lack of conformity.

5.4 Unpacking and inner-company transport



Usually the clamping device is packed vertically. Depending on the size it has threaded bores in the circumference of the clamping device for assembling the eye bolts.

In these threaded bores lifting eye bolts can be screwed in.

To safely lift the clamping device out of the package it must be hooked into a crane depending on the weight.

For transporting with transport trolley the clamping device must be positioned in standing condition. Make sure that a non-slip pad has been laid.

All tools and accessories which are not in scope of delivery are marked as optional in the operating instructions.

- Two people are required for this task.
- Special tools required:
 - Crane from weight 15 kg
 - Eye bolts



Fig. 9

1. Screw lifting eye bolts into the thread in the circumference of the clamping device.
2. Hook the load-handling equipment into the lifting eye bolts.
3. Use a crane to carefully lift the clamping device out of the transport packaging and put it down on a stable, level substrate.
4. Prevent the clamping device against rolling away.

5.5 Packaging

About the packaging

Individual packages are packed according to the expected transport conditions. Environmentally-friendly materials have been used exclusively for the packaging.

Packaging should protect the specific components from transport damage, corrosion, and other damage until installation. Therefore do not destroy the packaging, remove it just before installation.



The packed goods are sealed in foil airtight and packed in cartons. See the »Technical Data« section for the specific weight of the respective sizes.

Handling packaging materials

Dispose of packaging materials in accordance with the respectively valid statutory regulations and local guidelines.



NOTE!

Improper disposal causes environmental damage!

Packaging materials are valuable raw materials and in many cases they can be reused, or they can be effectively treated and recycled.

- Dispose of packaging materials in an environmentally responsible manner.
- Comply with locally applicable disposal guidelines. If necessary commission a specialized company to dispose of packaging.

5.6 Storing



Under certain circumstances instructions for storage and subsequent storage are affixed to the packages that extend beyond the requirements cited here.

Comply with these instructions accordingly.

Storage of packages Only store packages under the following conditions:

- Do not store outdoors.
- Store in a dry and dust-free location
- Do not expose to aggressive media
- Protect from direct sunlight
- Avoid mechanical vibration
- Storage temperature: 15 bis 35 °C
- Relative humidity: max. 60 %
- For storage periods longer than 3 months:
 - Check the general condition of all parts and the packaging at regular intervals.
 - Touch up or re-apply anti-corrosion agents as needed

Subsequent storage of the clamping device

Only re-store the clamping device under the following conditions:

- Thoroughly clean the clamping device prior to subsequent storage [see section »Cleaning«]
- Thoroughly oil and grease the clamping device. [see section »Cleaning«]
- Store the clamping device in airtight foil
- The clamping device must be stored securely in position. If this is not guaranteed, use a suitable container for the clamping device or equip the shelf with a circumferential securing edge.

6 Assembly



WARNING!

During the initial installation of the product severe injuries may occur.

- The initial installation must be done only by qualified personnel.
- All screws remaining in the clamping must be tightened firmly.
- All tools and keys must be removed after installation.
- Always wear personal protective equipment!

6.1 Pre-consideration

- Screws are tightened according to the size of the screw and the general torque.
To avoid axis-parallel warpage under load and to get stiffness turn in the screws evenly.
- To avoid precision error clean the screw joint surfaces and also the mating surfaces, see »Maintenance«.
The ex works wetting of the plate surfaces and the clamping element is only corrosion protection. It's not functionally lubricated.
- The insertion of lubricant is provided only on the mechanical surfaces. Pay attention to the instructions for lubricants in the chapter »Maintenance«.
- Avoid too much lubricant on the bearing surface, as this can cause face runout.
- Seal rings [e.g. o-ring, quad-ring seal] and sealing surfaces must be lubricated.
Note the information in the chapter »Maintenance«.
- Note that the function surfaces [plate surface, mating surface, cone surface and seal surface] may not be damaged.



CAUTION!

Wear safety shoes during the assembly and maintenance work.

Make sure that the starting of the spindle is impossible.

6.2 Preparations

The total weight of the clamping device depends on the size and can be as much as 43 kg.

Depending on the weight, to safely lift the clamping device out of the package and position it in the machine it must be hooked into a crane.



WARNING!

Danger of injury due to falling components!

When mounting components can fall and cause severe injury and material damage.

- Two people are always required for this task.
- Use a crane.
- For assembly on a vertically suspended spindle always use a suitable mounting aid.

If the clamping device is delivered in combination with a flange, the flange must be assembled before the clamping device!

Special tools required:

- Allen wrench
- Oil stone
- Crane
- Eye bolts

1. Loosen and remove the draw bolt.

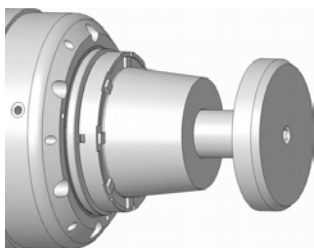

Fig. 10

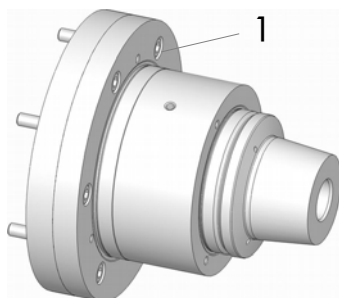

Fig. 11

2. Loosen, unscrew and remove the cylindrical screws [1] in the clamping device; use an allen wrench.

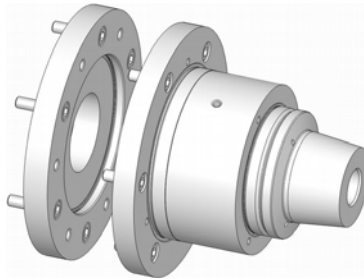

Fig. 12

3. Remove the flange from the clamping device.
4. Clean the mating surfaces at flange and clamping device with a soft, lint-free cloth and remove all oil and grease residues.
5. Hone the mating surfaces on the spindle flange with an oil stone.

6.3 Assembly

The segmented mandrel is delivered in assembled condition and with pre-assembled draw bolt.

The assembly differs depending on the machine to which the clamping device is to be assembled. It is to distinguish:

- Assembly to a machine spindle
- Assembly to a bayonet
- Assembly to a clamping mechanism
- Assembly to a hs dock / ms dock
- Assembly to a quick-change interface
- Assembly to a mandoteX interface



WARNING!

Danger of injury due to unexpected startup of the tool spindle!

Unexpected start up of the tool spindle can cause severe injury.

- Prior to switching on automatic mode close all protective doors or hoods that are present on the machine tool.
- After assembly, unscrew all eye bolts from the adapter and the clamping device and remove them from the interior of the machine.
- Only run the machine tool in set-up mode or jog mode.



WARNING!

Risk of injury!

Bending in the working area of the machine can cause severe head injuries!



CAUTION

Risk of injury!

When operating the clamping device without changing parts [segmented clamping bushing, workpiece end-stop] there is a higher danger of crushing injuries due to the stroke of movable components of the clamping device.

Increased danger by uncontrolled initiation of the clamping process [for example, by incorrect installation of the power supply or faulty programming].



CAUTION!

Risk of injury!

Unexpected start up of the tool spindle can cause severe injury.

- Make sure that the system is pressure-free and that a restart of the machine can be excluded!



Risk of injury!

Contamination of the mechanism can influence/reduce the stroke, thus the clamping force is reduced and thus, the workpiece is not properly tightened and can be thrown out.

- Clean the product regularly [see chapter »Maintenance and service«].



Risk of injury!

If the axial clamping force is too low clamped workpiece may be thrown out.

If the axial clamping force is too high severe damages of the components of the clamping device may occur the throwing out of the workpiece.

- Before operation set the operation pressure back to operation level.
- The axial clamping force should be checked and adjusted regularly!
- The dimension of the workpieces should be checked regularly [clamping- \emptyset]!



Transport!

- For transport always use a suitable clamping means / crane.
- Make sure that a rolling / falling of the clamping device is not possible.



WARNING!

Danger of injury due to vertical suspended spindle!

Bending into the machine work area when assembling overhead can cause severe head injuries.

- Secure components prior to overhead assembly.
- For assembly on a vertically suspended spindle always use a suitable mounting aid.

6.3.1 Assembling the flange [optional]



NOTE!

Material damage due to wrong tightening torque of the cylindrical screws in the spindle flange!

The tightening torque of the cylindrical screws is prescribed by the spindle or machine manufacturer. Incorrect tightening torque of the cylindrical screws in the flange can cause significant material damage on the clamping device and on the machine.

- Only tighten the cylindrical screws of the spindle with the torque prescribed by the spindle or machine manufacturer.



Fig. 13

1. Put the machine in set up mode.
2. Wipe off the mating surfaces of the machine spindle with a soft, lint-free cloth and remove all oil and grease residues.
3. Lift the flange into the machine by hand or with the aid of a crane and place it on the machine spindle. Position the flange on the machine spindle with the aid of the bores.
4. Screw all cylindrical screws into the flange with an allen wrench and hand tighten in a cross pattern.
5. Now adjust the clamping device, see »Adjusting the concentricity of the spindle flange«.



NOTE!

Material damage is possible if the eye bolts are left in the spindle flange!

Eye bolts that are left in the clamping device can significantly damage or even destroy lathe, clamping device and workpiece.

- Always remove eye bolts immediately after mounting the clamping device in the lathe.

6.3.2 Adjusting the concentricity of the spindle flange



NOTE!

Material damage due to insufficient face run and concentricity!

Due to insufficient face run and concentricity workpieces can be damaged during processing.

- After each mounting check, and if necessary readjust, the face run and concentricity of the clamping device.

Auxiliary material required:

- Dial indicator
- Rubber mallet
- Torque wrench

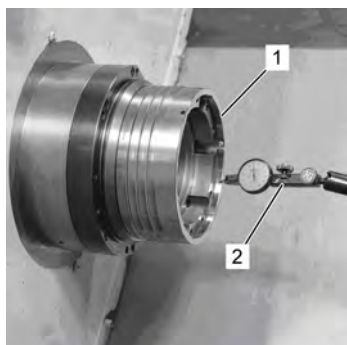

Fig. 14

1. Wipe off the mating surfaces of the spindle flange with a soft, lint-free cloth and remove all oil and grease residues.
2. Place the magnetic base of the dial indicator on the inside of the machine.
3. Place the dial indicator for concentricity on the fit of the spindle flange.

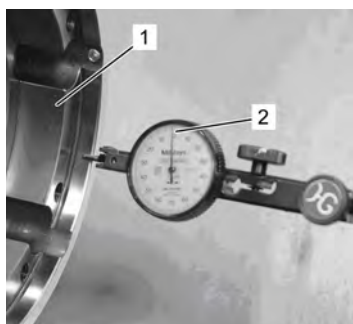

Fig. 15

4. Adjust the spindle flange in such a manner that the dial indicator shows the value »0« [$\leq 0,005$ mm].

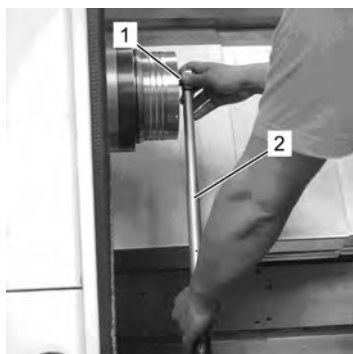

Fig. 16

5. Tighten all cylindrical screws with a torque wrench in a cross pattern [see section »Screw tightening torque«].



For exact adjustment, if necessary loosen the cylindrical screws a little, repeat the adjusting and retighten the cylindrical screws in a cross pattern.

6.3.3 Checking face run and concentricity

1. Place the magnetic base of the dial indicator on the inside of the machine.
2. Place the dial indicator for concentricity on the inside edge of the spindle flange and check the concentricity [$\leq 0,005$ mm].

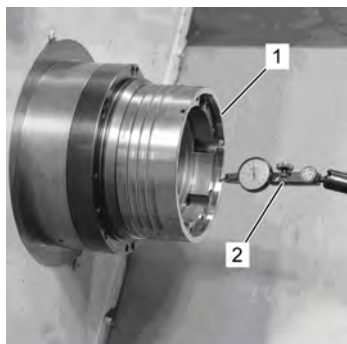

Fig. 17

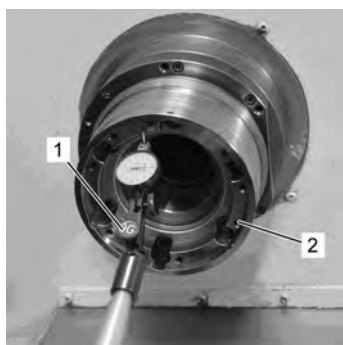

Fig. 18

3. Place the dial indicator for face run on the outer edge of the mating surface, check the face run [$\leq 0,005$ mm].
4. If face run and/or concentricity are larger than the maximum permissible value:
 - Disassemble the flange.
 - Clean all mating surfaces of spindle and spindle flange.
 - Re-assemble the flange.
 - Repeat the adjusting.

6.3.4 Assembling the quick-change machine adapter

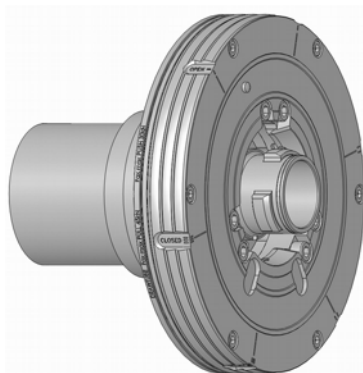

Fig. 19

The assembly of the quick-change machine adapter to the machine is described in the manual of the machine adapter.

6.3.5 Assembly of the segmented mandrel [machine spindle]

Two people are required for this task!

Special tools required:

- Allen wrench
- Crane
- Eye bolts

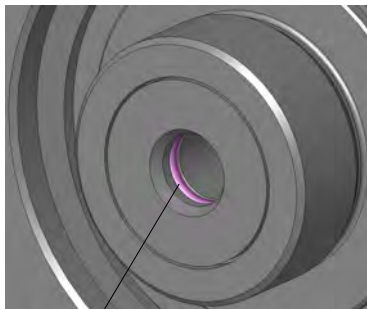

1 Fig. 20

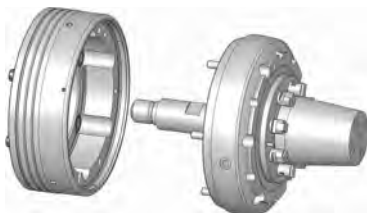

Fig. 21

1. Put the machine in set up mode.
2. Remove all tools from the interior of the machine.
3. Set the clamping pressure of the machine tool on the lowest setting.
4. Move the drawtube of the machine tool into front stop position.
5. If an LAK adapter is available make sure that the O-ring [see figure] is present and greased.
6. Put the segmented mandrel on the pre-assembled flange on the machine spindle by using a crane.
7. Screw the segmented mandrel by its threaded adapter on the drawtube of the machine or on the drawtube adapter till end.
8. Turn back the segmented mandrel until the bolt hole circles fit.
9. Screw in all cylindrical screws into the segmented mandrel with an allen wrench and tighten them only finger-tight in a cross pattern.



NOTE!

Before operating the segmented mandrel must be adjusted, see chapter »Checking and adjusting the face run and the concentricity«.

6.3.6 Assembly of the segmented mandrel [bayonet]

Two people are required for this task!

Special tools required:

- Allen wrench
- Crane and eye bolts from weight 15 kg.

1. Put the machine in set up mode.
2. Remove all tools from the interior of the machine.
3. Set the clamping pressure of the machine tool on the lowest setting.
4. Move the drawtube of the machine tool into front stop position.
5. Put the segmented mandrel on the pre-assembled flange on the machine spindle by using a crane.
6. Secure the clamping device by turning it in the bayonet.
7. Screw in all cylindrical screws into the segmented mandrel with an allen wrench and tighten them only finger-tight in a cross pattern.

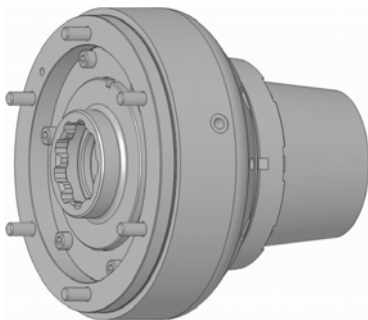

Fig. 22



NOTE!

Before operating the segmented mandrel must be adjusted, see chapter »Face run and concentricity«.

6.3.7 Assembly of the segmented mandrel [clamping mechanism]

Two people are required for this task!

Special tools required:

- Allen wrench
- Crane and eye bolts from weight 15 kg.



WARNING!

Crushing danger due to machine movement!

Due to the design of the drawtube it may not always be avoided that in the assembly of drawtube adapter and the clamping unit / clamping device there is a gap between machine and clamping device.

Crushing danger, that can cause severe injury.

- Never reach into the gap between machine / spindle flange and clamping device!

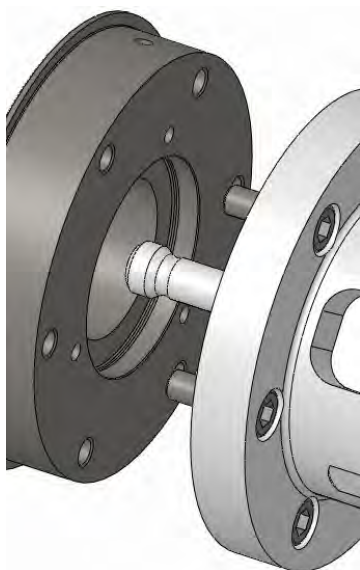

Fig. 23

1. Put the machine in set up mode.
2. Remove all tools from the interior of the machine.
3. Set the clamping pressure of the machine tool on the lowest setting.
4. Move the drawtube of the machine tool into front stop position, the clamping mechanism of the machines loosens.
5. Put the segmented mandrel on the pre-assembled flange [optionally] on the machine spindle by using a crane.
6. Insert the draw bolt of the clamping device into the clamping mechanism of the machine.
7. Screw in all cylindrical screws into the segmented mandrel with an allen wrench and tighten them only finger-tight in a cross pattern.

6.3.8 Assembly of the segmented mandrel [ms dock / hs dock]

Two people are required for this task

Special tools required:

- Allen wrench
- Crane and eye bolts from weight 15 kg.



Clean all mating surfaces of actuating unit and segmented mandrel before each assembly!

ms dock



Fig. 24

hs dock



Fig. 25

1. Move the connecting thread of the actuation into front end position.
2. Screw the segmented mandrel by its thread onto the pre-assembled actuation unit.
3. Screw in the mounting screws and tighten them firmly.

6.3.9 Assembly of the segmented mandrel [quick change-over interface]

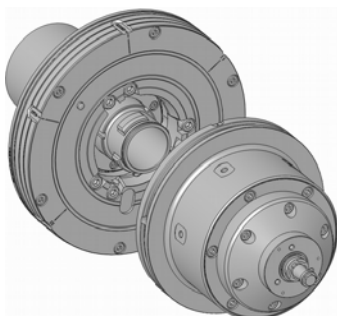

Fig. 26

The assembly of the segmented mandrel from the quick change machine adapter is described in the manual of the machine adapter.

6.3.10 Assembly of the segmented mandrel [mandoteX]

For the assembly of the segmented mandrel to a mandoteX interface pay attention to the manual of the mandoteX.

6.3.11 Face run and concentricity



NOTE!

Material damage due to insufficient face run and concentricity!

Due to insufficient face run and concentricity can follow unsatisfying work results.

- After each mounting check, and if necessary readjust, the face run and concentricity of the clamping device.

Special tools required:

- dial indicator
- rubber mallet
- torque wrench

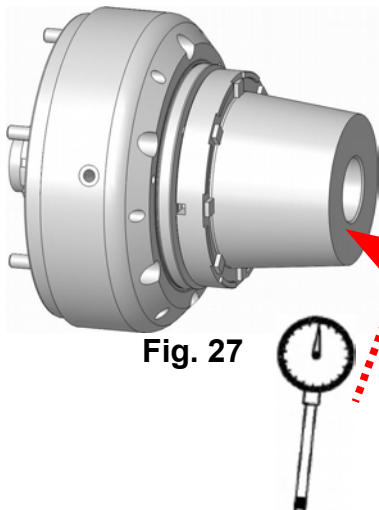

Fig. 27

Checking face run

1. Clean the clamping cone of the segmented mandrel with a soft, lint-free cloth and remove all oil and grease residues.
2. Place the magnetic base of the dial indicator on the inside of the machine.
3. Check the face run of the segmented mandrel [$\leq 0,005$ mm].

If the face run is larger than the maximum permissible value: Clean all mating surfaces of segmented mandrel and clamping unit and reassemble the clamping device.

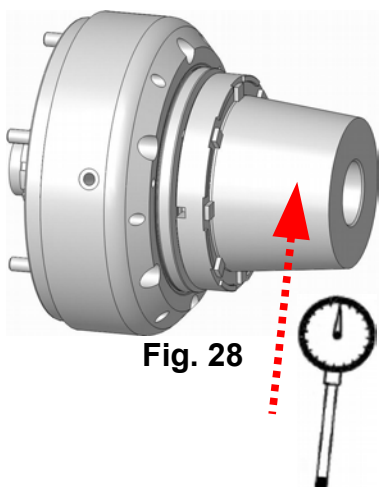

Fig. 28

Checking and adjusting face run and concentricity

1. Place the magnetic base of the dial indicator on the inside of the machine.
2. Place the dial indicator for concentricity on the clamping cone.
3. Adjust the segmented mandrel in such a manner that the dial indicator shows the value »0« [$\leq 0,005$ mm].



For exact adjustment, if necessary loosen the cylindrical screws only a little and retighten in a cross pattern.

4. Tighten the cylindrical screws] crosswise with the required tightening torque, see »Maintenance«.



CAUTION

Risk of injury!

When operating the clamping device without changing parts [segmented clamping bushing, workpiece end-stop] there is a higher danger of crushing injuries due to the stroke of movable components of the clamping device.

Increased danger by uncontrolled initiation of the clamping process [for example, by incorrect installation of the power supply or faulty programming].

6.3.12 Assembling of the workpiece end-stop

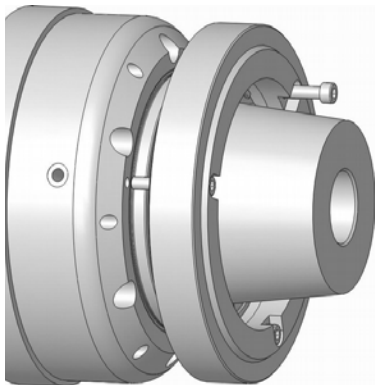

Fig. 29

Special tools required:

- Torque wrench

1. Put the machine tool in set up mode.
2. Remove all tools from the interior of the machine.
3. Set the axial clamping force of the machine tool on the lowest setting.
4. Move the drawtube of the machine tool into the front stop position.
5. Put the workpiece end-stop on the segmented mandrel.
6. Screw in all cylindrical screws into the workpiece end-stop and tighten them clockwise with an allen wrench [see section »Screw tightening torque«].



WARNING!

Risk of injury!

Tools and gages that are thrown out of the machine can cause injury.

- Remove all tools and gages from the working area of the machine before the machine is started up.



CAUTION

Damage of the clamping device!

If the axial clamping force is too low the clamped workpieces may be thrown out.

- Before operation set the axial clamping force back to operation level.
- The operating axial clamping force should be checked and adjusted regularly!



WARNING!

Slipping danger due to escaping hydraulic fluid!

Escaping [sprayed out] hydraulic oil from adjacent machine components can cause serious personal injuries.

- Make sure that all o-rings/seals for the hydraulic / pneumatic interfaces are available and in undamaged condition.
- Make sure that the clamping device is empty and leakage of hydraulic fluid is avoided.



WARNING!

Risk of injury due to stored energy!

The workpiece end-stop may be designed with disc springs. These disc springs are under permanent tension! The release of the stored energy can cause injuries!

- The screws which are secured by sealing wax may not be opened.
- By loosening the corresponding screws they have to be operated continuously alternately to reduce the clamping pressure to a minimum!
- Particularly cautious approach is required!
- Always wear personal protective equipment!

6.3.13 Assembly of the segmented clamping bushing RD

Special tools required:

- Allen wrench

1. Put the machine in set up mode.
2. Remove all tools from the interior of the machine.
3. Set the axial clamping force of the machine on the lowest setting.
4. Move the drawtube of the machine tool into the front stop position.
5. Put the segmented clamping bushing on the segmented mandrel.

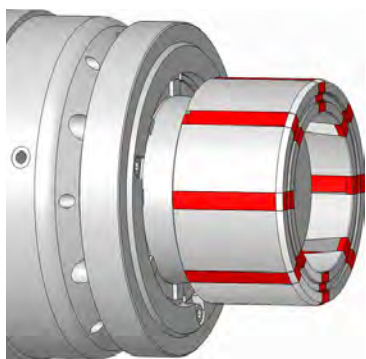

Fig. 30



NOTE!

The grooves at the segmented clamping bushing must engage to the corresponding keys in the segmented mandrel.

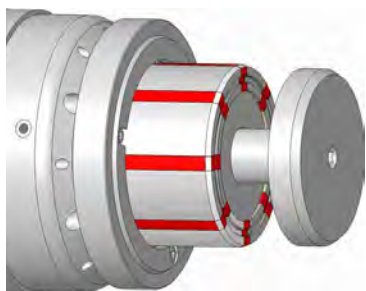

Fig. 31

6. Screw in the draw bolt.
7. Tighten the draw bolt by using an allen wrench [not in scope of delivery] with the required tightening torque [see marking on the draw bolt].



WARNING!

Risk of injury due to thrown off parts!

During operation of the clamping device with inadequate tightened draw bolt, the draw bolt may loosen, the draw bolt and the workpiece can be thrown away.

- Always tighten the draw bolt with the required and marked tightening torque!



WARNING!

Risk of injury!

Tools and gages that are thrown out of the machine can cause injury.

- Remove all tools and gages from the working area of the machine before the machine is started up.



Risk of injury!

Contamination of the mechanism can influence/reduce the stroke, thus the clamping force is reduced and thus, the workpiece is not properly tightened and can be thrown out.

- Clean the product regularly [see chapter »Maintenance and service«].



Risk of injury!

If the axial clamping force is too low clamped workpiece may be thrown out.

If the axial clamping force is too high severe damages of the components of the clamping device may occur the throwing out of the workpiece.

- Before operation set the operation pressure back to operation level.
- The axial clamping force should be checked and adjusted regularly!
- The dimension of the workpieces should be checked regularly [clamping- \emptyset]!

6.4 Workpiece



WARNING!

Risk of injury due to thrown out parts!

During clamping of the workpiece and the processing parts can be thrown and cause severe injuries and property damage.

- Check the clamping diameter of the workpiece.
- Only clamp workpieces that meet the dimensional requirements.
- For clamping very long workpieces use in addition a tailstock / a steady rest for support.
- Do not exceed the maximum permissible axial clamping force.
- Make sure that the applied axial clamping force is set correctly [neither too high nor too low].



NOTE!

Material damage due to inappropriate workpieces!

- Only clamp workpieces that meet the dimensional requirements.
- For the dimensional requirements see chapter 3 »Technical data«.



CAUTION

Risk of injury!

When placing the workpiece:

- Make sure that the hands / fingers may not be clamped when inserting the workpiece!

6.5 Tests



NOTE!

Material damage due to damaged products!

A damaged or incomplete clamping device and/or adapter can significantly damage or even destroy the machine tool and the workpiece.

- Only use undamaged and complete products.
- If in doubt contact the manufacturer.

Ensure the following points prior to each installation and start-up of the clamping device:

- All cylindrical screws of the add on clamping device must be present and tightened with the proper tightening torque.
- All rubber segments must be intact; this means that they are neither torn, nor are they porous at any point.
- All edges and bearing surfaces are intact; this means that they are neither broken nor do they show any signs of wear.
- The set speed of the machine tool should not exceed the maximum permissible speed of the clamping device.
- The maximum drawtube force specified on the perimeter of the clamping device must not be exceeded.
- The axial clamping force of the machine must be sufficiently high.
- All assembly tools must be removed from the interior of the machine.
- Clamping device and workpiece must be compatible – check the clamping diameter regularly.
- The workpiece must be clamped into the clamping device with sufficient workpiece tension.
- Do a measurement of clamping force.

6.6 Control of the stroke position



WARNING!

Crushing danger from moving parts!

Crushing danger from moving parts during controlling the stroke position!

Gaps, caused while controlling the stroke position, can cause severe injury.

- Only do the controlling of the stroke position with assembled changing parts.
- Only run the machine in set-up mode or jog mode.
- Do not reach into moving parts or handle moving parts during operation.
- Note the gap dimensions of moving parts.
- Wearing of gloves / [PSA] is required!

6.7 Activities after production is concluded

1. Move the clamping device into unclamped position.
2. Switch off the machine tool and safeguard it from being switched on again.
3. Open the protective door or hood.
4. Clean the clamping device and a possibly mounted add on clamping device and adapter of chips and production residues using a soft, lint-free cloth and oil them lightly.
5. Close the protective door or hood.

7 Disassembly

If there is break in production that lasts longer than 3 days, the clamping device must be disassembled and properly stored in accordance with the manufacturer's specifications [see section »Transport, packaging, storage«].

Prior to disassembling:

- Put the machine in set up mode.
- Remove fuels and auxiliary materials, as well as residual processing materials and dispose of these items in an environmentally-responsible manner.

7.1 Safety

Safeguarding against restart



DANGER!

Life-threatening danger if restarted without authorization

When disassembling there is danger of the energy supply being switched on inadvertently. This poses a life-threatening hazard for persons in the danger zone.

- Prior to starting the tasks switch off all energy supplies and safeguard them from being switched on again.



WARNING!

Danger of injury due to falling components!

When mounting components can fall and cause severe injury and material damage.

- Two people are always required for this task.
- Use a crane.
- For assembly on a vertically suspended spindle always use a suitable mounting aid.



Transport!

- For transport always use a suitable clamping means / crane.
- Make sure that a rolling / falling of the clamping device is not possible.



WARNING!

Danger of injury due to vertical suspended spindle!

Bending into the machine work area when assembling overhead can cause severe head injuries.

- Secure components prior to overhead assembly.
- For assembly on a vertically suspended spindle always use a suitable mounting aid.

7.2 Disassembling the clamping device

Two people are required for this task

Special tools required:

- Allen wrench
- Crane and eye bolts

7.2.1 Disassembly of the segmented clamping bushing

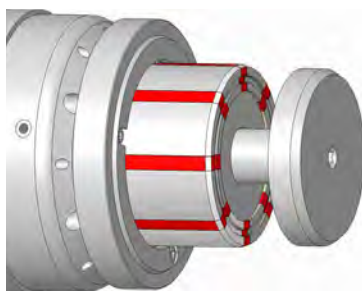

Fig. 32

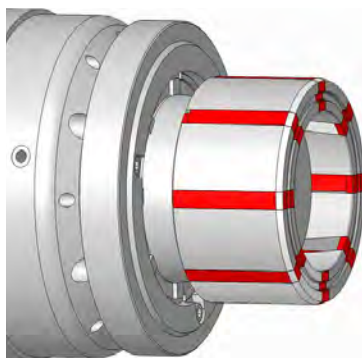

Fig. 33

1. Put the machine tool in set up mode.
2. Remove all tools from the interior of the machine.
3. Reduce the axial clamping force of the machine to lowest level.
4. Move the drawtube of the machine tool into the front stop position.
5. Loosen the draw bolt by using an allen wrench and remove it completely.
6. Remove the segmented clamping bushing from the segmented mandrel.

7.2.2 Disassembling the workpiece end-stop

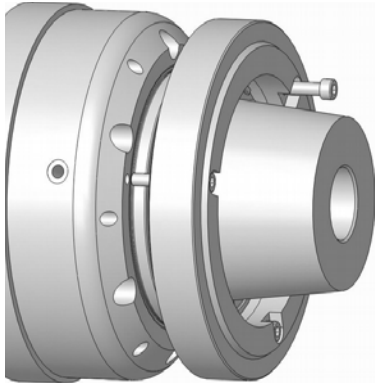

Fig. 34

1. Put the machine tool in set up mode.
2. Remove all tools from the interior of the machine.
3. Reduce the axial clamping force of the machine to lowest level.
4. Move the drawtube of the machine tool into the front stop position.
5. Loosen, unscrew and remove the cylindrical screws.
6. Remove the workpiece end-stop from the segmented mandrel.

7.2.3 Disassembly of the segmented mandrel [machine spindle]

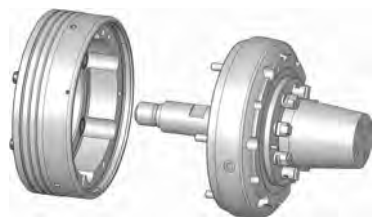

Fig. 35

1. Put the machine tool in set up mode.
2. Remove all tools from the interior of the machine.
3. Reduce the axial clamping force of the machine to lowest level.
4. Move the drawtube of the machine tool into the front stop position.
5. Loosen, unscrew and remove the cylindrical screws.



WARNING!

Danger of injury due to falling components!

The segmented mandrel is not secured yet and can fall down and cause severe injury and material damage.

- Two people are always required for this task.
- For assembly on a vertically suspended spindle always use a suitable mounting aid.

6. Unscrew the segmented mandrel and the threaded adapter from the drawtube of the machine.
7. Screw in the eye bolts and secure the clamping device at a crane.
8. Remove the segmented mandrel from the flange by using a crane.

7.2.4 Disassembly of the segmented mandrel [bayonet]

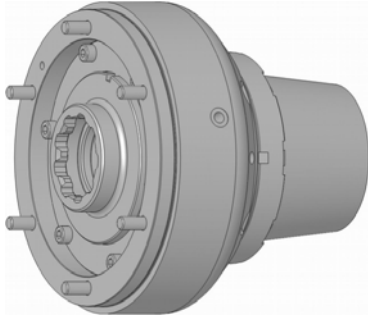

Fig. 36

1. Put the machine tool in set up mode.
2. Remove all tools from the interior of the machine.
3. Reduce the axial clamping force of the machine to lowest level.
4. Move the drawtube of the machine tool into the front stop position.
5. Loosen, unscrew and remove the cylindrical screws.
6. Screw in the eye bolts and secure the clamping device at a crane.
7. Unlock the clamping device by turning it in the bayonet.
8. Remove the segmented mandrel from the flange by using a crane.

7.2.5 Disassembling the segmented mandrel [clamping mechanism]

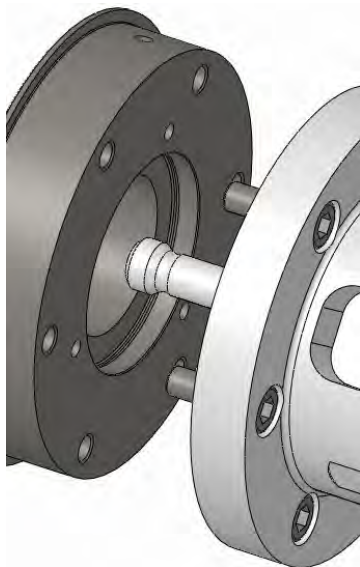

Fig. 37

1. Put the machine tool in set up mode.
2. Remove all tools from the interior of the machine.
3. Reduce the axial clamping force of the machine to lowest level.
4. Move the drawtube of the machine tool into the front stop position.
5. Loosen, unscrew and remove the cylindrical screws.
6. Loosen the clamping mechanism of the machine.
7. Remove the segmented mandrel from the flange by using a crane.

7.2.6 Disassembling the segmented mandrel [ms dock / hs dock]



Fig. 38

Fig. 39

1. Move the connecting thread of the actuation into front end position.
2. Loosen and remove the mounting screws.
3. Unscrew the segmented mandrel by its thread from the actuation unit.

7.2.7 Disassembling the segmented mandrel [quick change interface]

The clamping device can be provided with an interface:

1. centroteX / centroteX-V
2. capteX B / capteX D

The disassembly of the clamping device from on of the named interfaces is described in the manual of the respective interface.

7.2.8 Disassembly of the segmented mandrel [mandoteX]

The disassembly of the clamping device from a mandoteX interface is described in the manual of the mandoteX.

7.2.9 Disassembling the spindle flange

From weight 15 kg the task requires two people, or use a crane.

Special tools required:

- Torque wrench
- Allen wrench
- Crane and eye bolts from weight 15 kg

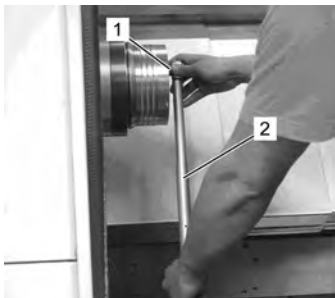

Fig. 40

1. If necessary mount the eye bolts [see section »Unpacking and inner-company transport«].
2. Loosen all cylindrical screws [1] with a torque wrench [2] in a cross pattern.
3. Remove all cylindrical screws from the spindle flange.

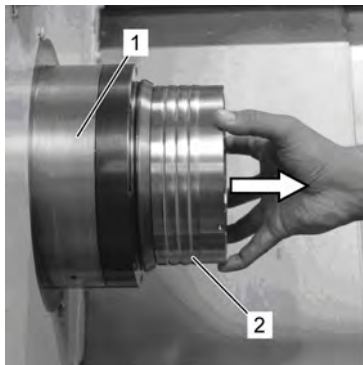

Fig. 41

4. Take the spindle flange [2] down from the machine spindle [1] by hand or with the aid of load-handling equipment and lift it out of the machine tool.
5. Wipe off the mating surfaces of the machine spindle with a soft, lint-free cloth and remove all oil and grease residues.
6. Remove all tools from the interior of the machine.

7.2.10 Disassembly of the quick-change machine adapter [optional]

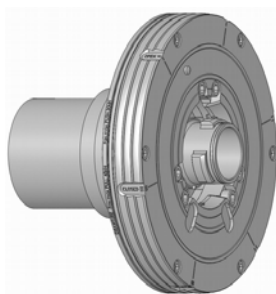

Fig. 42

The disassembly of the quick change machine adapter is described in the manual of the machine adapter.

7.3 Subsequent storage of the clamping device

The clamping device must be cleaned and treated with corrosion protection for subsequent storage [see section »Cleaning«].



NOTE!

The storage conditions are specified in the section »Transport, packaging and storage«.

7.4 Disposal

If a return or disposal agreement has not been concluded, then recycle disassembled components.



NOTE!

Improper disposal causes environmental damage!

Lubricants and other auxiliary materials are subject to treatment as special waste, and should only be disposed of by approved specialist companies!

Local municipal authorities or specialized disposal companies provide information on environmentally-responsible disposal.

8 Maintenance

Environmental protection

Comply with the following instructions for environmental protection when performing maintenance work:

- At all lubricating points where lubricant is applied by hand, remove escaping, used, or excess grease, and dispose of it in accordance with applicable local regulations.
- Collect used oil in suitable containers and dispose of it in accordance with applicable local regulations.

8.1 General

Cleanliness of the appropriate end-stop as well as the guidance diameters are conditions for reaching the concentricity and perpendicularity tolerances. Clean these surfaces with an appropriate cleaner.



WARNING!

Risk of injury!

Always comply with the safety data sheets and guidelines provided by the manufacturer.



CAUTION

Danger of injury due to loss of clamping force!

Fouling of the clamping device can cause the clamping device to lose considerable clamping force.

- Always comply with the maintenance and cleaning intervals specified in this manual.
- In conjunction with the maintenance intervals, regularly check the maintenance status of the clamping device through clamping force measurements.



Risk of injury!

Slipping while the lubricating with a grease gun can lead to severe cuts!

8.2 Cleaning



NOTE!

Material damage if cleaned with compressed air!

Cleaning the clamping device with compressed air can force metal chips into thread and grooves. This can damage or even destroy the clamping device.

- Never clean the clamping device with compressed air!

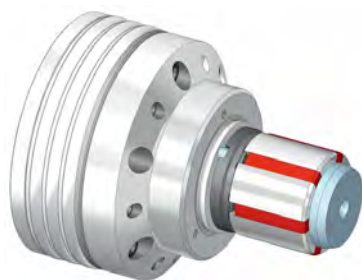

Fig. 43

- Auxiliary material required:
 - Ester-free, non-polar cleaning agent
 - Soft, lint-free cloth
- 1. Disassemble the clamping device [see section »Disassembling the clamping device«].
- 2. Clean all components listed below with cleaning agent and a cloth; remove all oil and grease residues:
 - Flange
 - Clamping unit / segmented clamping bushing
 - Taper of the segmented mandrel
 - Reception and inner thread for the clamping unit in the segmented mandrel
 - Workpiece end-stop [option]
 - Cylindrical screws

8.3 Preservation



Fig. 44

- Special tools required:
 - Universal grease 2085/0003
 - Grease gun
 - Oil stone
 - Soft, lint-free cloth
- 1. Disassemble the clamping device [see section »Disassembling the clamping device«].
- 2. Hone all the bearing surfaces of the clamping device with an oil stone.
- 3. Lightly grease all cylindrical screws. Remove excess grease with a cloth.
- 4. Remount the clamping device.
- 5. Screw all cylindrical screws into the clamping device again and tighten them finger-tight.
 - ! For subsequent storage tightening the cylindrical screws finger-tight suffices. This facilitates re-commissioning and protect the cylindrical screws.
- 6. Lightly grease all interior and outer surfaces of the clamping device. Remove excess grease with a cloth.
- 7. Pack the clamping device airtight in foil. Place it on a level, impact-free storage location and safeguard it from falling.

8.4 Use of lubricant

With the usage of lubricant you may only use grease that corresponds to the requirements concerning bond, pressure-stability and solubility in lubricating coolant. In addition no dirt particles may be in the grease; they cause run errors if they come in in-between two mating surfaces.

We recommend for this the following lubricant:

HAINBUCH grease

See optional Accessories

Alternatives:

Lubricant	Manufacturer	Product
Universal grease	OKS	OKS 265
	MicroGleit	GP 355
	Klüber	QNB 50
	Zeller & Gmelin	DIVINOL SD24440
	Bremer & Leguill	RIVOLTA W.A.P.
Special grease	Klüber	MICROLUBE GL 261

8.5 Maintenance schedule

Maintenance tasks are described in the sections above that are required for optimal and trouble-free operation.

If increased wear is detected during regular inspections, then reduce the required maintenance intervals according to the actual indications of wear.

Contact the manufacturer, [see the service address on the back] if you have questions concerning maintenance tasks and intervals.

Interval	Maintenance task
Daily	Visual inspection and complete cleaning in case of heavy contamination [see section »Cleaning«], especially at the clamping and end-stop face to avoid damages at the clamping device and the clamping elements early.
	Check the query of the final position of the machine
	Perform a static clamping force measurement.
Each 36 operating hour	Clean the clamping device and the clamping unit [see section »Cleaning«].
	Clean the clamping taper [see section »Cleaning«].
	Grease the clamping device [see section »Preservation«].
Every 6 months	Completely disassemble and clean the clamping unit [see section »Cleaning«].



For proper operation of the coolant feed a pre-filtering with duplex filter [mesh size 100 µm, PI 3754] is necessary. The duplex filter is mounted on the coolant cleaning system.

8.6 Bolt torque

Metric ISO thread

The guide values for bolt tightening torque for achieving the highest permissible pre-tension for metric ISO thread are specified in Nm in the table.

- Total friction coefficient $\mu_{\text{tot}} = 0,12$

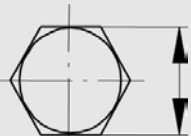
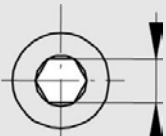
Diameter	 [mm]	 [mm]	Torque for screw quality 10.9 [Nm]
M 4	7	3	4
M 5	8	4	7
M 6	10	5	12
M 8	13	6	25
M 10	17	8	50
M 12	19	10	100
M 16	24	14	220
M 20	30	17	400
M 24	36	19	600

The table shows the prescribed values.

Knowledge of the applicable guidelines and configuration criteria are the prerequisites.



Consider any different screw tightening torques [e.g. with aluminum components].

- If necessary, different screw tightening torques are given in Chapter 1.

9 Trouble shooting

Possible fault causes and the tasks to correct these faults are described in the following section.

If faults occur more frequently, the maintenance intervals must be shortened to correspond to the actual system load.

Contact the manufacturer if there are faults that cannot be corrected by following the instructions below; see the service address on the back of this operating instruction.

9.1 Safety

Trouble shooting

The following always applies:

1. For faults that pose a direct danger for personnel and or property immediately execute the emergency-stop function of the machine.
2. Determine the cause of the fault.
3. If correction of the fault requires work in the danger zone, put the machine in set-up mode.
4. Immediately inform the responsible parties at the installation site of the fault.
5. Depending on the type of fault, either have authorized specialized personnel correct the fault, or correct it yourself.



The trouble shooting table provided below lists personnel who are authorized to correct the fault.

6. If there is a fault that was not caused by the clamping device the cause of the fault may be in the machine area. See the operating manual for the machine in this regard.

9.2 Trouble shooting table

Fault	Possible cause	Fault correction	Corrected by
Clamping device does not open or the release stroke is insufficient.	Fouling between the draw mechanism and the draw bolt	Disassemble the draw bolt and the segmented clamping bushing, move the drawtube back and clean the area. [see section »Disassembly of the segmented clamping bushing«].	Specialist
	Dimensional deviation of the drawtube adapter	Check the dimensions of the drawtube adapter and correct them if necessary.	Specialist
Clamping force is too low	Workpiece is over-dimensioned	Replace with a suitable segmented clamping bushing.	Specialist
	Insufficient hydraulic pressure on the clamping cylinder	Check the machine-side hydraulic aggregate	Hydraulic specialist
	Defective clamping cylinder or blocked drawtube	Contact the machine manufacturer	Machine manufacturer
	For special variants: Compression springs fatigued [at permanent tension]	Replace compression springs	Specialist
Eccentric dimensional deviation on the workpiece	Concentricity error of the segmented mandrel	Check the concentricity on the clamping taper at the segmented mandrel and correct it if necessary [see section »Checking and adjusting the face run and concentricity«]	Specialist
Dimensional deviation on the workpiece	Contaminated clamping taper	Disassemble the segmented clamping bushing and clean the clamping cone [see section »Cleaning«].	Specialist
Formal defect on the workpiece	Elastic deformation of feedstock that is subject to formal defects. After machining, the workpiece returns to its original form.	Use feedstock with fewer formal defects. If technically justifiable reduce the clamping force.	Specialist

Fault	Possible cause	Fault correction	Corrected by
Marks on the clamping surface	Point or linear workpiece clamping	Replace with a segmented clamping bushing that has a smoother clamping surface	Specialist
	Dimensional difference between the workpiece diameter and the clamping bore is too big and/or too small.	Replace with a segmented clamping bushing that has a suitable clamping diameter.	Specialist

9.3 Start-up after corrected fault

After correcting the fault execute the following steps to start up again:

1. Reset the emergency-stop device
2. Acknowledge the fault on the machine tool controller
3. Ensure that no one is in the danger zone
4. Start the machine tool

10 Appendix

10.1 Service Hotline

Order Hotline

Quickly ordered and delivered. A call is all it takes:
+49 7144. 907-333

Schedule Hotline

Current status of your order? Just call:
+49 7144. 907-222

24h emergency call

Has there been a crash or other technical emergency?

Our experts are at your service around the clock:
+49 7144. 907-444

10.2 Representatives

The sales partners and service employees listed below are available for further consultation or support.

10.2.1 Europe

Austria

HAINBUCH in Austria GmbH
SPANNENDE TECHNIK
Pillweinstr. 16
5020 Salzburg
Phone +43 662 825309
Fax +43 662 62500720
E-mail: verkauf@hainbuch.at
Internet: www.hainbuch.at

Bulgaria

Aton MI Ltd
63 Shipchenski prohod Blvd., floor: 9,
office No. 92
1574 Sofia
Phone +359 879050951
E-mail: sales@smartcnc.eu
Internet: www.smartcnc.eu

Denmark

Jørn B. Herringe A/S
Ramsømagle, Syvvejen 31
4621 Gadstrup
Phone +45 46170000
Fax +45 46170001
E-mail: sales@jbh-tools.dk
Internet: www.jbh-tools.dk

Belgium

BIS Technics bvba/sprl
Zevenputtenstraat 20
3690 Zutendaal
Phone +32 89518890
Fax +32 89518899
E-mail: info@bistechnics.com
Internet: www.bistechnics.com

Czech Republic

TMC CR s.r.o.
Masná 27/9
60200 Brno
Phone +420 533433722
Fax +420 548217219
E-mail: info@tmccr.cz
Internet: www.tmccr.cz

Estonia, Latvia, Lithuania

DV-Tools OÜ
Peterburi tee 34/4
11415 Tallinn
Phone +372 6030508
Fax +372 6030508
E-mail: info@dv-tools.ee
Internet: www.dv-tools.ee

Finland

Oy Maanterä Ab
PL 70 Keinumäenkuja 2
01510 Vantaa
Phone +358 29006130
Fax +358 290061130
E-mail: maantera@maantera.fi
Internet: www.maantera.fi

Great Britain

HAINBUCH UK Ltd.
WORKHOLDING TECHNOLOGY
Newbury
Keys Business Village, Keys Park Road
Hednesford, Staffordshire
WS12 2HA
Phone +44 1543 278731
Fax +44 1543 478711
Mobile +44 7980212784
E-mail: nick.peter@hainbuch.co.uk
Internet: www.hainbuch.com

Greece

CNCMECHANICS
Afroditis 16 - N. Ionia
14235 Athens
Phone +30 6948 860408
Fax +30 210 2753725
E-mail: info@cncmechanics.gr
Internet: www.cncmechanics.gr

Ireland

HAINBUCH UK Ltd.
WORKHOLDING TECHNOLOGY
Newbury
Keys Business Village, Keys Park Road
Hednesford, Staffordshire
WS12 2HA
Phone +44 1543 278731
Fax +44 1543 478711
Mobile +44 7980212784
E-mail: nick.peter@hainbuch.co.uk
Internet: www.hainbuch.com

Netherlands

BIS Specials
[Brandenburg Industry Service Dongen B.V.]
Regelinkstraat 11
7255 CC Hengelo [Gld.]
Phone +31 313482566
Fax +31 313482569
E-mail: info@bisspecials.com
Internet: www.bisspecials.com

France

HAINBUCH France Sarl
TECHNIQUE DE SERRAGE
1600 route de la Lième
ZI Lons Perrigny
39570 Perrigny
Phone +33 384876666
Fax +33 384876677
E-mail: info@hainbuch.fr
Internet: www.hainbuch.fr

Great Britain

Leader Chuck Systems Limited
PO Box 16050
Tamworth, B77 9JP
Tel. +44 1827 700000
Fax +44 1827 707777
E-mail: information@leaderchuck.com
Internet: www.leaderchuck.com

Hungary

GIMEX Hydraulik GmbH
Selyem utca 1.
9025 Győr
Phone +36 96525588
Fax +36 96427239
E-mail: info@gimex.hu
Internet: www.gimex.hu

Italy

HAINBUCH Italia srl
TECNICA DEL SERRAGGIO
Via Caduti di Nassiriya 5
22063 Cantu' [Co]
Phone +39 0313355351
Fax +39 031611570
E-mail: info@hainbuchitalia.it
Internet: www.hainbuchitalia.it

Norway

Onstad Maskin A/S
Chr. H. Blomsgt. 13
3717 Skien
Phone +47 35532373/74
Fax +47 35532375
E-mail: postmaster@onstadmaskin.no
Internet: www.onstadmaskin.no

Poland

BIM Sp. z o.o.
Złotniki, ul. Kobaltowa 6
62-002 Suchy Las
Phone +48 616232041
Fax +48 616232040
E-mail: bim@bim-polska.pl
Internet: www.bim-polska.pl

Romania

Banatech srl. – connecting technologies
Ep. Miron Cristea 26
325400 Caransebes, Caras Severin
Phone +40 255517175
Fax +40 355814125
Mobile +40 749220553
E-mail: office@banatech.ro
Internet: www.banatech.ro

Slovakia

TNS s.r.o.
Vácka ulica 4109/10
01841 Dubnica N/V
Phone +421 424450873
Fax +421 424440406
E-mail: tns@tnssro.sk
Internet: www.tnssro.eu

Slovenia

Elmetool d.o.o.
Prvomajska ulica 62
5000 Nova Gorica
Phone +386 53303300
Fax +386 53303304
E-mail: info@elmetool.si
Internet: www.elmetool.si

Sweden

HAINBUCH Svenska AB
SPÄNNANDE TEKNIK
Kemistvägen 17
18379 Täby
Phone +46 87327550
Fax +46 87327650
E-mail: hainbuch@hainbuch.se
Internet: www.hainbuch.se

Turkey

Hidkom
Organize Sanayi Bölgesi
75. Yil CD. Demirciler Sit. B Blok No.2
16159 Nilüfer / Bursa
Phone +90 2242438292
Fax +90 2242436365
E-mail: hidkom@hidkom.com
Internet: www.hidkom.com

Poland

ARCO Andrzej Rudenko
UL.NIEZAPOMINAJKI 6
05-500 NOWA IWICZNA
Phone +48 223532705
Fax +48 222702722
E-mail: info@arcotools.pl
Internet: www.arcotools.pl

Russia

ROSNA Engineering LLC
Sveaborgskaya street, 12, Letter »A«, office 20N,
196105 Saint-Petersburg
Phone +7 812 4016767-100
Fax +7 812 4016767
E-mail: rosna@rosna.spb.ru
Internet: www.rosna.spb.ru

Slovakia

TMC CR s.r.o.
Masná 27/9
60200 Brno
Phone +420 533433722
Fax +420 548217219
E-mail: info@tmccr.cz
Internet: www.tmccr.cz

Spain, Portugal

ATM S.L
C/. Gran Bretanya, 16
Pol. Ind. Pla de Llerona
08520 Les Franqueses del Vallès
[Barcelona]
Phone +34 938700885
Fax +34 938791689
E-mail: atm.sl@atmbarcelona.com

Switzerland

Utilis AG
Präzisionswerkzeuge
Kreuzlinger Straße 22
8555 Müllheim
Phone +41 527626262
Fax +41 527626200
E-mail: info@utilis.com
Internet: www.utilis.com

10.2.2 North america

Canada

HAINBUCH America Corp.
WORKHOLDING TECHNOLOGY
W129 N10980 Washington Dr.
Germantown, WI 53022
U.S.A
Phone +1 4143589550
Fax +1 4143589560
E-mail: sales@hainbuchamerica.com
Internet: www.hainbuch.com

Mexico

HAINBUCH México
TECNOLOGÍA EN SUJECIÓN
Edificio La Torre
Blvd. Adolfo López Mateos #901 Piso 6,
Centro
38000 Celaya, Gto.
Phone +52 46122163928
E-mail: sales@hainbuch.mx
Internet: www.hainbuch.mx

Canada

Representative for: Ontario, Québec
J.Winkel & Associates Inc.
6516 Warbler Lane
L5N 6E1 Mississauga, Ontario
U.S.A
Phone +1 9058248335
E-mail: info@winkel.ca
Internet: www.winkel.ca

USA

HAINBUCH America Corp.
WORKHOLDING TECHNOLOGY
W129 N10980 Washington Dr.
Germantown, WI 53022
Phone +1 4143589550
Fax +1 4143589560
E-mail: sales@hainbuchamerica.com
Internet: www.hainbuch.com

10.2.3 South america

Argentina

HAINBUCH America Corp.
WORKHOLDING TECHNOLOGY
W129N10980 Washington Dr.
Germantown, WI 53022
U.S.A
Phone +1 4143589550
Fax +1 4143589560
E-mail: sales@hainbuchamerica.com
Internet: www.hainbuchamerica.com

Brasil

Sanposs Tecnologia
Suprimentos e Consultoria Internacional Ltda.
Rua Cândia n° 65 - Jardim do Mar
CEP: 09726-220
São Bernardo do Campo - São Paulo
Phone +55 11 41266711
E-mail: tsci@sanposs.com.br
Internet: www.sanposs.com.br

10.2.4 Asia

China

HAINBUCH Shanghai Co. Ltd.
WORKHOLDING TECHNOLOGY
Room 611-612 BaoHong Center
No. 7755 Zhongchun Road
Minhang District, Shanghai 201101
Phone +86 2120916384
Fax +86 2120916383
E-mail: sales@hainbuch.cn
Internet: www.hainbuch.cn

Indonesia

PT. STAHL ARBEIT
Simprug Ruko Plaza
Jl. Taman Simprug Raya Blok B1 No. 01
Jababeka Cikarang Baru 17530
Phone +62 8111080041
Phone +62 8111080042
Fax. +62 2128518061
E-mail: info@stahl-arbeit.com
Internet: www.stahl-arbeit.com

India

M'la Sales Corporation
5, Yeshwantnagar
Telco-Century Enka Road
Pimpri, Pune 411018
Phone +91 2065003776
Phone +91 2065002369
E-mail: sales@m-la-sales.com
Internet: www.m-la-sales.com

Israel

MTM Ltd.
Hakishor str. 26
5886708 Holon
Phone +972 36479560
Fax +972 36479578
E-mail: sales@mtm.co.il
Internet: www.mtm.co.il

Japan

NK Works Co LTD
2-17-17 Iwamoto-cho, Chiyoda-ku
Tokyo, 101-0032
Phone +81 338645411
Fax +81 338646752
E-mail: info@nk-works.co.jp
Internet: www.nk-works.co.jp

Malaysia, Singapore & Vietnam

Jebsen & Jessen Technology [S] Pte Ltd.
Industrial Services Division
18 Enterprise Road
Singapore 629824
Phone +65 63053692
Mobile +65 93803737
Fax +65 63053699
E-mail: phillip_lee@jjsea.com
Internet: www.jjsea.com

Thailand

HAINBUCH [Thailand] Co. Ltd
WORKHOLDING SOLUTIONS
2/25 Sukhapiban 2 Road Prawet,
Prawet, Bangkok 10250
Phone +662329 0622/23
Fax +662329 0624
E-Mail: info@hainbuch.co.th
Internet: www.hainbuch.com

Korea

Kims International Co., Ltd.
5, MTV 26-ro 58bun-gil, Siheung-Si,
Gyeonggi-Do, South Korea 429-450
Phone: +82 7043387908
Fax: +82 314970613
E-Mail: kimi@kimigroup.co.kr

Taiwan

GSTC Technology Co., Ltd.
No. 418, Youn-Chun East 1st Rd
Taichung City 40877, Taiwan'
Phone +88 6423805678
Fax +88 6423805511
E-mail: gstc@seed.net.tw
Internet: www.gstctech.com.tw

10.2.5 Australia

Australia

Romheld Automation Pty Ltd
Unit 30 115 Woodpark Road
Smithfield . NSW. 2164
Phone +61 297211799
Fax +61 297211766
E-mail: sales@romheld.com.au
Internet: www.romheld.com.au

10.2.6 Africa

South Africa

Retecon [PTY] Ltd.
P.O. Box 1472
1620 Kempton Park
Phone +27 119768600
Fax +27 113942471
E-mail: tools@retecon.co.za
Internet: www.retecon.co.za

Index

A			
Accessories.....			
Grease.....	23		
Grease gun.....	23		
optional.....	21		
Adjusting.....			
Segmented mandrel.....	40		
Spindle flange.....	34		
Assembly.....			
Flange.....	33		
Preparations.....	29		
Segmented clamping bushing RD.....	43		
Segmented mandrel [bayonet].....	37		
Segmented mandrel [capteX].....	39		
Segmented mandrel [clamping mechanism].....	38		
Segmented mandrel [machine spindle].....	36		
segmented mandrel [mandoteX].....	40		
segmented mandrel [ms dock / hs dock].....	39		
Workpiece.....	45		
Workpiece end-stop.....	41		
B			
Bolt torque.....	59		
Brief description.....	21		
C			
Check.....	19		
Cleaning.....	56		
Control of the stroke position.....	47		
D			
dangers.....	12		
Disassembly.....			
Segmented clamping bushing.....	49		
Segmented mandrel [bayonet].....	51		
Segmented mandrel [clamping mechanism].....	51		
Segmented mandrel [hs dock / ms dock].....	52		
Segmented mandrel [machine spindle].....	50		
Segmented mandrel [mandoteX].....	52		
Segmented mandrel [quick change interface].....	52		
Spindle flange.....	53		
Workpiece end-stop.....	50		
Disposal.....		54	
E			
Environmental protection.....		17	
I			
Intended use.....		10	
L			
loads.....		13	
M			
Maintenance schedule.....		58	
mandoteX adapter.....		22	
misuse.....		11	
O			
Operating conditions.....		19	
Overview.....		20	
P			
Packaging.....		26	
Personal protective equipment.....			
Hard hat.....		12	
Protective gloves.....		12	
Protective goggles.....		12	
Protective work clothing.....		11	
Safety footwear.....		11	
Personnel requirements.....		9	
Power specifications.....		19	
Preservation.....		57	
R			
Representatives.....			
Africa.....		67	
Asia.....		66	
Australia.....		67	
Europe.....		63	
North america.....		66	
South america.....		66	
S			
Scope of delivery.....		7	
Segmented clamping bushing.....		22	
Spare parts.....		7	
Storing.....		27	
Structure.....		20	
Symbols on the packaging.....		24	
T			
Tests.....		46	
Transport.....			
Inner-company.....		25	

MANDO T211 RD – Appendix

Transport inspection.....	25
Trouble shooting.....	60
Trouble shooting table.....	61
Type designation.....	19

U	
Unpacking.....	25
use.....	10
W	
Workpiece end-stop.....	22

EC Declaration of conformity

EG-Konformitätserklärung im Sinne der EG-Richtlinie 2006/42/EG über Maschinen [Anhang II A] /

EC Declaration of conformity according to EC directive 2006/42/EC on machinery [Annex II A]

Original-Konformitätserklärung / Translation of original declaration of conformity

Hersteller / manufacturer: HAINBUCH GmbH Spannende Technik
Erdmannhäuser Straße 57
71672 Marbach
Deutschland

Diese Erklärung bezieht sich nur auf die Maschine in dem Zustand, in dem sie in Verkehr gebracht wurde; vom Endnutzer nachträglich angebrachte Teile und/oder nachträglich vorgenommene Eingriffe bleiben unberücksichtigt. Die Erklärung verliert ihre Gültigkeit, wenn das Produkt ohne Zustimmung umgebaut oder verändert wird.

This declaration relates exclusively to the machinery in the state in which it was placed on the market, and excludes components which are added and/or operations carried out subsequently by the final user. The declaration is no more valid, if the product is modified without agreement.

Hiermit erklären wir, dass die nachstehend beschriebene Maschine
Herewith we declare, that the machinery described below

Produktbezeichnung / **MANDO T211 RD**
product denomination:

allen einschlägigen Bestimmungen der Maschinenrichtlinie 2006/42/EG entspricht.
is complying with all essential requirements of the Machinery Directive 2006/42/EC.

Angewandte harmonisierte Normen / Harmonised Standards used:

- EN ISO 12100:2011-03 Sicherheit von Maschinen – Allgemeine Gestaltungsgrundsätze
Safety of Machinery – Basic concepts
- DIN EN 1550:1997 Sicherheitsanforderungen für die Gestaltung und Konstruktion von Spannfuttern für die Werkstückaufnahme /
Safety requirements for the design and construction of work holding chucks

Bevollmächtigter für die Zusammenstellung der technischen Unterlagen /
The person authorized to compile the relevant technical documentation:
HAINBUCH GmbH Spannende Technik
Konstruktionsleitung
Erdmannhäuser Straße 57
71672 Marbach
Deutschland



HAINBUCH GMBH · SPANNENDE TECHNIK
PO Box 1262 · 71667 Marbach / Erdmannhauser Strasse 57 · 71672 Marbach · Germany
Phone +49 7144.907-0 · Fax +49 7144.18826 · sales@hainbuch.de · www.hainbuch.com
24h-Emergency call +49 7144.907-444