

mandoteX. Machine adapter with short taper / cylinder fit

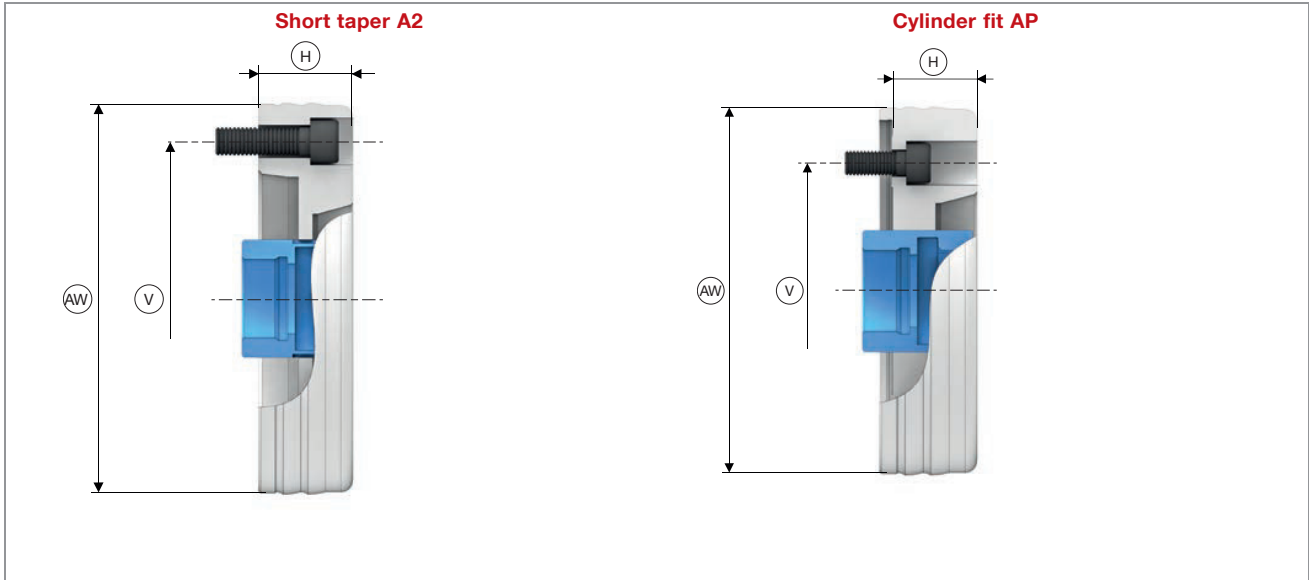

Spindle nose	DU	A2-5	A2-6	A2-8	AP140	AP170
Length [mm]	H	40			35	
Bolt hole circle	V	LK Ø 104,8 [6 x M10]	LK Ø 133,4 [6 x M12]	LK Ø 171,4 [6 x M16]	LK Ø 104,8 [6 x M10]	LK Ø 133,4 [6 x M12]
Outer Ø [mm]	AW	150	165	235	150	180
In stock		✓	✓	✓	✓	✓
Order no.		10646/0001	10646/0002	10646/0004	10646/0003	10646/0005

Machine spindle standard DIN 55026.